

BUILDING CHARACTERISTICS		CONSTRUCTION	
ELEMENT	CD		
Exterior Wall	19	COMMON BRK	60
Exterior Wall	31	VINYL SID	40
Roof Structure	03	GABLE/HIP	100
Roof Cover	03	COMP SHNGL	100
Interior Wall	05	DRYWALL	100
Interior Floor	14	CARPET	80
Interior Floor	12	HARDWOOD	20
Air Condition	03	CENTRAL	100
Heating Type	04	AIR DUCTED	100
Bedrooms		4	100
Bathrooms		3	100
Frame	01	NONE	100
Stories	1.	1.	100
Architectual	05	CONV	100
Units		0	100
Condition Adj	03	03	100
Kitchen Adjus	01	01	100
Quality	07	07	
DOR CODE	0100	SINGLE FAMILY	
MAP NUM		MKT AREA	06
NEIGHBORHOOD/LOC	26316.030	1.00/	

MARKET ADJUSTMENTS											
TYPE	MDL	EFF. AREA	TOT ADJ PTS	EFF. BASE RATE	REPL. COST NEW	AYB	EYB	ECON	FNCT	NORM	% COND
0100	01	2,853	117.6670	131.79	375,997	1984	1984	0	0	35.00	65.00

1 SINGLE FAM 100% - 2018 Heated Area: 2463 HX Base Yr 2018

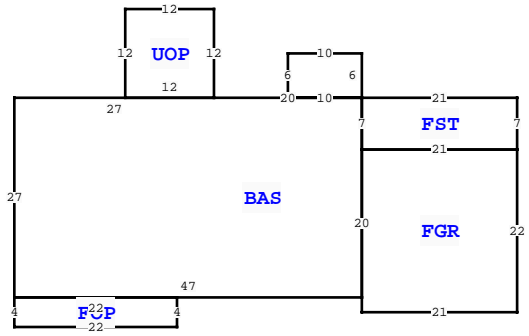
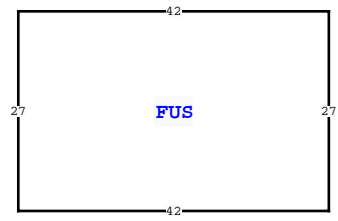

AREA TYPE	TOTAL GROSS AREA	PCT OF BASE	YEAR	TOT ADJ AREA	SUBAREA MARKET VALUE
BAS	1,329	100		1,329	113,847
FGR	462	55		254	21,759
FOP	88	30		26	2,228
FST	147	55		81	6,939
FUS	1,134	100		1,134	97,143
UOP	144	20		29	2,484
TOTALS	3,304			2,853	244,398

118 NW HERON GLN, LAKE CITY

BLD DATE		LGL DATE	
XF DATE		LAND DATE	04/14/2026
INC DATE		AG DATE	MLU

L N	OB/XF CODE	DESCRIPTION	BLD CAP	L	W	UNITS	UT	Adj R	ADJ UNIT PRICE	ORIG COND	YEAR ON	YEAR ACTUAL	Q	% COND	OB/XF MKT VALUE	NOTES
1	0190	FPLC PF	0	100	0	1.00	UT	1,200.00	1,200.00	100	0	0	3	100	1,200	
2	0166	CONC,PAVMT	0	100	0	1.00	UT	0.00	0.00	100	0	0	3	100	1,500	
3	0166	CONC,PAVMT	0	100	0	480.00	UT	2.00	2.00	100	1993	1993	3	100	960	

TOTAL OB/XF 3,660

L N	USE CODE	CLS	LAND USE DESCRIPTION	CAP	R D	LOC ZONE	FRONT	DEPTH	TOT LND UTS	UNIT TYPE	D T	DPH FACT	% COND	TOT ADJ	UNIT PRICE	ADJ UNIT PRICE	LAND VALUE	OTHER ADJUSTMENTS AND NOTES	YEAR	DENSITY	DECL	FRZ	YR	CONSRV
1	0100	C	SFR	100		00	0.00	0.00	1.00	LT		1.00	1.00	1.00	35,000.00	35,000.00	35,000							

COLUMBIA COUNTY PROPERTY			
VALUATION SUMMARY			PAGE 1 of 1
VALUATION BY			STANDARD
Tax Group: 2	Tax Dist:		
BUILDING MARKET VALUE			244,398
TOTAL MARKET OB/XF VALUE			3,660
TOTAL LAND VALUE - MARKET			35,000
TOTAL MARKET VALUE			283,058
SOH/AGL Deduction			112,241
ASSESSED VALUE			170,817
TOTAL EXEMPTION VALUE	HX HB	51,411	
BASE TAXABLE VALUE			119,406
TOTAL JUST VALUE			283,058
NCON VALUE			0
INCOME VALUE			
PREVIOUS YEAR MKT VALUE			283,058

PERMIT NUM	DESCRIPTION	AMT	ISSUED
000052115	Roof Replacement	12,981	01/20/2025

SALES DATA						
OFF RECORD Number	DATE	TYPE INST	Q / U	V / I	RSN CD	SALE PRICE
1342/0524	8/07/2017	WD Q	Q	I	01	171,500
GRANTOR: GIRISH & PREMALATHA B						
GRANTEE: HANLEY D & DAWN M C						
0541/0615	6/01/1984	WD Q	Q	V		18,000
GRANTOR:						
GRANTEE:						

BUILDING NOTES	

BUILDING DIMENSIONS	
BAS= N6 W10 S6 E10 W20 UOP= N12 W12 S12 E12\$ W27 S27 FOP= S4 E22 N4 W22\$ E47 FGR= S2E21 N22 W21 S20\$ N20 FST= E21 N7 W21 S7\$ N7\$ PTR= N30 FUS= N27 W42 S27 E42\$ S30\$.	