

BUILDING CHARACTERISTICS		CONSTRUCTION	
ELEMENT	CD		
Exterior Wall	19	COMMON BRK	100
Roof Structur	03	GABLE/HIP	100
Roof Cover	03	COMP SHNGL	100
Interior Wall	05	DRYWALL	100
Interior Floo	14	CARPET	80
Interior Floo	15	HARDTILE	20
Air Condition	03	CENTRAL	100
Heating Type	04	AIR DUCTED	100
Bedrooms		4	100
Bathrooms		3	100
Frame	02	WOOD FRAME	100
Stories	1.	1.	100
Architectual	05	CONV	100
Units		0	100
Condition Adj	03	03	100
Kitchen Adjus	01	01	100
Quality	06	06	
DOR CODE	0100	SINGLE FAMILY	
MAP NUM		MKT AREA	06
NEIGHBORHOOD/LOC	34316.070	1.00/	
AREA TYPE	TOTAL GROSS AREA	PCT OF BASE	YEAR
BAS	2,516	100	
FGR	648	55	
FOP	69	30	
FOP	260	30	
UDU	204	55	
UDU	228	55	
TOTALS	3,925		

MARKET ADJUSTMENTS												
TYPE	MDL	EFF. AREA	TOT ADJ PTS	EFF. BASE RATE	REPL. COST NEW	AYB	EYB	ECON	FNCT	NORM	% COND	
1	SINGLE FAM	0%	- 2021		427,434	2006	2006	0	0	19.00	81.00	
Heated Area: 2516 HX Base Yr												

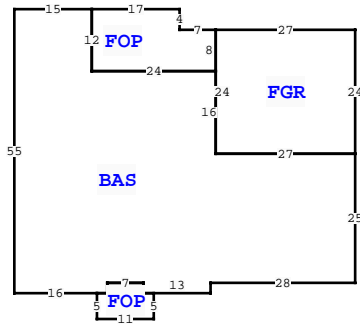
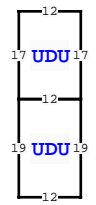

COLUMBIA COUNTY PROPERTY		PAGE 1 of 1
VALUATION SUMMARY		1
VALUATION BY	STANDARD	
Tax Group: 1	Tax Dist:	
BUILDING MARKET VALUE	346,222	
TOTAL MARKET OB/XF VALUE	29,082	
TOTAL LAND VALUE - MARKET	35,000	
TOTAL MARKET VALUE	410,304	
SOH/AGL Deduction	0	
ASSESSED VALUE	410,304	
TOTAL EXEMPTION VALUE	0	
BASE TAXABLE VALUE	410,304	
TOTAL JUST VALUE	410,304	
NCON VALUE	0	
INCOME VALUE		
PREVIOUS YEAR MKT VALUE	415,695	

PERMIT NUM	DESCRIPTION	AMT	ISSUED
000047313	Remodel	13,500	05/24/2023
000044539	Roof Replacement	27,090	05/26/2022
834	POOL	352	05/29/2008
3585	SFR	50	02/02/2006

SALES DATA						
OFF RECORD Number	DATE	TYPE INST	Q / U	V / I	RSN CD	SALE PRICE
1408/2078	3/24/2020	WD Q	Q	I	01	304,000
GRANTOR: BENJAMIN D & CAMERON						
GRANTEE: JUSTIN & DEANNA MOR						
1066/0103	11/22/2005	WD Q	Q	V		42,500
GRANTOR: RICHARD COLE AND DANI						
GRANTEE: SCOTT						

EXTRA FEATURES																	
L N	OB/XF CODE	DESCRIPTION	BLD	CAP	L	W	UNITS	UT	Adj R	ADJ UNIT PRICE	ORIG COND	YEAR ON	YEAR ACTUAL	Q	% COND	OB/XF MKT VALUE	NOTES
1	0166	CONC, PAVMT	0	0	0	0	2,876.00	UT	1.60	1.60	75	2006	2006	3	75	3,451	
2	0280	POOL R/CON	0	0	14	38	532.00	UT	70.00	70.00	100	2008	2008	3	58	21,599	
3	0169	FENCE/WOOD	0	0	0	0	384.00	UT	10.50	10.50	100	2008	2008	3	100	4,032	

818 NW SAVANNAH CIR, LAKE CITY
BLD DATE: LGL DATE: 04/14/2026 MLU
XF DATE: LAND DATE: AG DATE:
INC DATE:

BUILDING NOTES	

BUILDING DIMENSIONS
BAS= W15 S55 E16 FOP= S5 E11 N5 W2 N2 W7 S2 W2\$ E2 N2 E7 S2 E13N2 E28 N25 FGR= N24 W27 S24 E27\$ W27 N16 FOP= N8 W7 N4 W17 S12 E24\$ W24 N12\$ PTR= N30 UDU= N19 UDU= N17 W12 S17 E12\$ W12 S19 E12\$ S30\$.

LAND DESCRIPTION													TOTAL OB/XF												
L N	USE CODE	CLS	LAND USE DESCRIPTION	CAP	R D	LOC ZONE	FRONT	DEPTH	TOT LND UTS	UNIT TYPE	D T	DPH FACT	% COND	TOT ADJ	UNIT PRICE	ADJ UNIT PRICE	LAND VALUE	OTHER ADJUSTMENTS AND NOTES	YEAR	DENSITY	DECL	FRZ	YR	CONSRV	
1	0100	C	SFR	0		RSF-1	0.00	0.00	1.00	LT		1.00	1.00	1.00	35,000.00	35,000.00	35,000								