

BUILDING CHARACTERISTICS		CONSTRUCTION			
ELEMENT	CD				
Exterior Wall	19	COMMON BRK	100		
Roof Structur	03	GABLE/HIP	100		
Roof Cover	03	COMP SHNGL	100		
Interior Wall	05	DRYWALL	100		
Interior Floo	14	CARPET	90		
Interior Floo	11	CLAY TILE	10		
Air Condition	03	CENTRAL	100		
Heating Type	04	AIR DUCTED	100		
Bedrooms		3	100		
Bathrooms		3.5	100		
Frame	01	NONE	100		
Stories	2.	2.	100		
Architectual	05	CONV	100		
Units		0	100		
Condition Adj	03	03	100		
Kitchen Adjus	01	01	100		
Quality	07	07			
DOR CODE	0100	SINGLE FAMILY			
MAP NUM		MKT AREA	06		
NEIGHBORHOOD/LOC	33316.020	1.00/			
AREA TYPE	TOTAL GROSS AREA	PCT OF BASE	YEAR	TOT ADJ AREA	SUBAREA MARKET VALUE
BAS	1,423	100		1,423	133,221
FGR	575	55		316	29,583
FUS	1,147	100		1,147	107,381
PTO	230	5		12	1,123
UOP	32	20		6	562
TOTALS	3,407			2,904	271,871

MARKET ADJUSTMENTS											
TYPE	MDL	EFF. AREA	TOT ADJ PTS	EFF. BASE RATE	REPL. COST NEW	AYB	EYB	ECON	FNCT	NORM	% COND
0100	01	2,904	128.5977	144.03	418,263	1988	1988	0	0	35.00	65.00
1 SINGLE FAM 100% - 2000 Heated Area: 2570 HX Base Yr 2000											

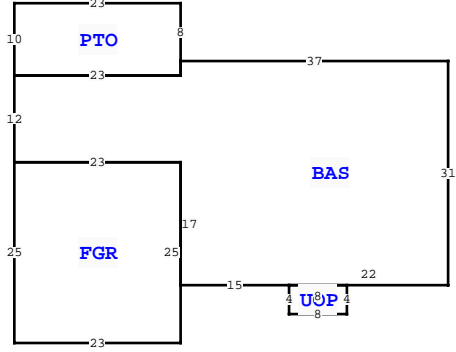
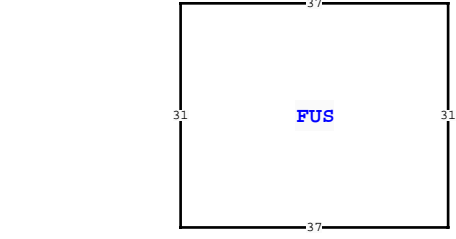

325 SW SWEETBREEZE DR, LAKE CITY

BLD DATE		LGL DATE	
XF DATE		LAND DATE	04/03/2025
INC DATE		AG DATE	MLU

EXTRA FEATURES											
L N	OB/XF CODE	DESCRIPTION	BLD	CAP	L	W	UNITS	UT	Adj R	ADJ UNIT PRICE	ORIG COND
1	0166	CONC,PAVMT	0	100	0	0	1.00	UT	0.00	0.00	100
2	0170	FPLC 2STRY	0	100	0	0	1.00	UT	2,750.00	2,750.00	100
3	0169	FENCE/WOOD	0	100	0	0	1.00	UT	0.00	0.00	100
											2014
											2014
											3
											100
											50

TOTAL OB/XF 4,960

LAND DESCRIPTION												TOTAL OB/XF												
L N	USE CODE	CLS	LAND USE DESCRIPTION	CAP	R D	LOC ZONE	FRONT	DEPTH	TOT LND UTS	UNIT TYPE	D T	DPH FACT	% COND	TOT ADJ	UNIT PRICE	ADJ UNIT PRICE	LAND VALUE	OTHER ADJUSTMENTS AND NOTES	YEAR	DENSITY	DECL	FRZ	YR	CONSRV
1	0100	C	SFR	100		RSF	1200.00	230.00	1.00	LT		1.00	1.00	1.00	35,000.00	35,000.00	35,000							

COLUMBIA COUNTY PROPERTY			PAGE 1 of 1	2
VALUATION SUMMARY			STANDARD	
VALUATION BY	Tax Group: 2		Tax Dist:	
BUILDING MARKET VALUE	271,871			
TOTAL MARKET OB/XF VALUE	4,960			
TOTAL LAND VALUE - MARKET	35,000			
TOTAL MARKET VALUE	311,831			
SOH/AGL Deduction	98,108			
ASSESSED VALUE	213,723			
TOTAL EXEMPTION VALUE	51,411		HX HB	
BASE TAXABLE VALUE	162,312			
TOTAL JUST VALUE	311,831			
NCON VALUE	0			
INCOME VALUE				
PREVIOUS YEAR MKT VALUE	311,831			

PERMIT NUM	DESCRIPTION	AMT	ISSUED
30983	MAINT/ALTR	45	04/26/2013

SALES DATA						
OFF RECORD Number	DATE	TYPE INST	Q U	V I	RSN CD	SALE PRICE
1253/1273	4/23/2013	QC	U	I	30	100

GRANTOR: STEVEN E SUMMERS  
GRANTEE: MARLENE M SUMMERS  
0873/0040 1/15/1999 WD Q I 152,000  
GRANTOR: GIEBEIG  
GRANTEE: SUMMERS

BUILDING NOTES											
----------------	--	--	--	--	--	--	--	--	--	--	--

BUILDING DIMENSIONS											
BAS= W37 PTO= N8 W23 S10 E23 N2\$ S2 W23 S12 FGR= S25 E23 N25 W23\$ E23 S17 E15 UOP= S4 E8 N4 W8\$ E22 N31\$ PTR=N20 FUS= N31 W37 S31 E37\$S20\$.											