

| ELEMENT | CD | CONSTRUCTION |
|--------------------|----|-------------------|
| Exterior Wall | 19 | COMMON BRK 100 |
| Roof Structur | 08 | IRREGULAR 100 |
| Roof Cover | 03 | COMP SHNGL 100 |
| Interior Wall | 05 | DRYWALL 100 |
| Interior Floor | 14 | CARPET 90 |
| Interior Floor | 15 | HARDTILE 10 |
| Air Condition | 03 | CENTRAL 100 |
| Heating Type | 04 | AIR DUCTED 100 |
| Bedrooms | | 4 100 |
| Bathrooms | | 3 100 |
| Frame | 01 | NONE 100 |
| Stories | 1. | 1. 100 |
| Architectual Units | 05 | CONV 100 0 100 |
| Condition Adj | 03 | 03 100 |
| Kitchen Adjus | 01 | 01 100 |

| MARKET ADJUSTMENTS | | | | | | | | | | | | | |
|---|-----|-----------|-------------|----------------|----------------|------|------|------|------|------|--------|-------|--|
| TYPE | MDL | EFF. AREA | TOT ADJ PTS | EFF. BASE RATE | REPL. COST NEW | AYB | EYB | ECON | FNCT | NORM | % COND | | |
| 0100 | 01 | 4,954 | 116.0072 | 129.93 | 643,673 | 1997 | 2005 | 0 | 0 | 0 | 20.00 | 80.00 | |
| 1 SINGLE FAM 0% - 2026 Heated Area: 4115 HX Base Yr | | | | | | | | | | | | | |

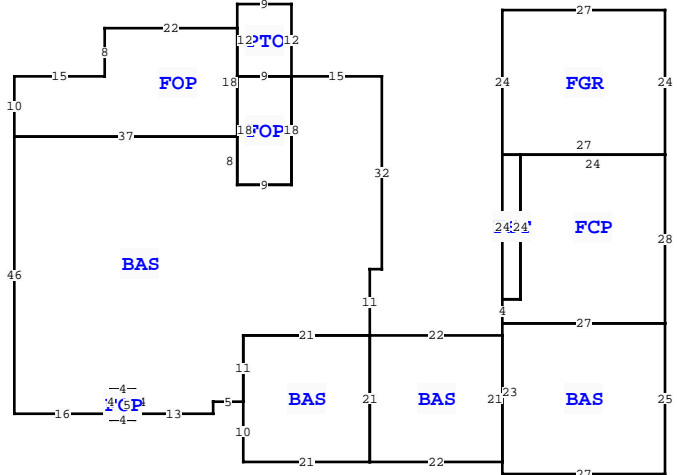

| AREA TYPE | TOTAL GROSS AREA | PCT OF BASE | YEAR | TOT ADJ AREA | SUBAREA MARKET VALUE |
|-----------|------------------|-------------|------|--------------|----------------------|
| BAS | 441 | 100 | | 441 | 45,839 |
| BAS | 462 | 100 | | 462 | 48,022 |
| BAS | 675 | 100 | | 675 | 70,162 |
| BAS | 2,537 | 100 | | 2,537 | 263,706 |
| FCP | 684 | 25 | | 171 | 17,774 |
| FGR | 648 | 55 | | 356 | 37,004 |
| FOP | 20 | 30 | | 6 | 624 |
| FOP | 162 | 30 | | 49 | 5,094 |
| FOP | 546 | 30 | | 164 | 17,047 |
| FST | 72 | 55 | | 40 | 4,158 |

** This building has 12 Sub-Areas

| | | | |
|----------|-----------|------------|-----|
| BLD DATE | LGL DATE | 04/22/2026 | MLU |
| XF DATE | LAND DATE | | |
| INC DATE | AG DATE | | |

| EXTRA FEATURES | | | | | | | | | | | | | | | | | |
|----------------|------------|-------------|-----|-----|-----|-----|----------|----|----------|----------------|-----------|---------|-------------|---|--------|-----------------|-------|
| L N | OB/XF CODE | DESCRIPTION | BLD | CAP | L | W | UNITS | UT | Adj R | ADJ UNIT PRICE | ORIG COND | YEAR ON | YEAR ACTUAL | Q | % COND | OB/XF MKT VALUE | NOTES |
| 1 | 0166 | CONC, PAVMT | 0 | 0 | 117 | 4 | 468.00 | UT | 1.50 | 1.50 | 100 | 1997 | 1997 | 3 | 100 | 702 | |
| 2 | 0190 | FPLC PF | 0 | 0 | 0 | 0 | 1.00 | UT | 1,200.00 | 1,200.00 | 100 | 1997 | 1997 | 3 | 100 | 1,200 | |
| 3 | 0280 | POOL R/CON | 0 | 0 | 18 | 36 | 648.00 | UT | 70.00 | 70.00 | 100 | 1998 | 1998 | 3 | 40 | 18,144 | |
| 4 | 0166 | CONC, PAVMT | 0 | 0 | 0 | 0 | 1,052.00 | UT | 1.50 | 1.50 | 100 | 1998 | 1998 | 3 | 100 | 1,578 | |
| 5 | 0260 | PAVEMENT-A | 0 | 0 | 10 | 258 | 2,580.00 | UT | 0.75 | 0.75 | 100 | 1998 | 1998 | 3 | 100 | 1,935 | |

| TOTAL OB/XF | | | | | | | | | | | | | | 23,559 | | | |
|-------------|--|--|--|--|--|--|--|--|--|--|--|--|--|--------|--|--|--|
|-------------|--|--|--|--|--|--|--|--|--|--|--|--|--|--------|--|--|--|

| LAND DESCRIPTION | | | | | | | | | | | | | | TOTAL OB/XF 23,559 | | | | | | | | | |
|------------------|----------|-----|----------------------|-----|-----|----------|-------|-------|-------------|-----------|-----|--------|---------|--------------------|----------------|------------|-----------------------------|------|---------|------|-----|----|--------|
| L N | USE CODE | CLS | LAND USE DESCRIPTION | CAP | R D | LOC ZONE | FRONT | DEPTH | TOT LND UTS | UNIT TYPE | D T | % COND | TOT ADJ | UNIT PRICE | ADJ UNIT PRICE | LAND VALUE | OTHER ADJUSTMENTS AND NOTES | YEAR | DENSITY | DECL | FRZ | YR | CONSRV |
| 1 | 0100 | C | SFR | 0 | | 00 | 0.00 | 0.00 | 1.00 | LT | | 1.00 | 1.00 | 60,000.00 | 60,000.00 | 60,000 | | | | | | | |

| VALUATION BY | | | | STANDARD | | | |
|---------------------------|--|-----------|--|----------|--|--|--|
| Tax Group: 3 | | Tax Dist: | | | | | |
| BUILDING MARKET VALUE | | | | 514,938 | | | |
| TOTAL MARKET OB/XF VALUE | | | | 23,559 | | | |
| TOTAL LAND VALUE - MARKET | | | | 60,000 | | | |
| TOTAL MARKET VALUE | | | | 598,497 | | | |
| SOH/AGL Deduction | | | | 0 | | | |
| ASSESSED VALUE | | | | 598,497 | | | |
| TOTAL EXEMPTION VALUE | | | | 0 | | | |
| BASE TAXABLE VALUE | | | | 598,497 | | | |
| TOTAL JUST VALUE | | | | 598,497 | | | |
| NCON VALUE | | | | 0 | | | |
| INCOME VALUE | | | | 0 | | | |
| PREVIOUS YEAR MKT VALUE | | | | 590,785 | | | |

LAND:1:1: 5.03 AC
SALE:1:1: LOT 8

| PERMIT NUM | DESCRIPTION | AMT | ISSUED |
|------------|------------------|--------|------------|
| 000050864 | Roof Replacement | 32,000 | 09/19/2024 |
| 29301 | GARAGE | 383 | 04/11/2011 |
| 14253 | ADDN SFR | 95 | 07/09/1998 |
| 14147 | POOL | 145 | 06/16/1998 |
| 11768 | SFR | 395 | 10/17/1996 |

| SALES DATA | | | | | | |
|-------------------|-----------|-----------|-------|-------|--------|------------|
| OFF RECORD Number | DATE | TYPE INST | Q / U | V / I | RSN CD | SALE PRICE |
| 1547/675 | 8/18/2025 | WD Q | Q | I | 01 | 794,443 |

GRANTOR: KEEN DALLAS HART
GRANTEE: FLINT STEVEN WAYNE
1532/1676 | 1/31/2025 | LE U | I 14 | 100
GRANTOR: HART DALLAS LYNN FKA
GRANTEE: KEEN RAYMOND AND DA

| BUILDING NOTES | | | | | | | | | | | | | |
|----------------|--|--|--|--|--|--|--|--|--|--|--|--|--|
|----------------|--|--|--|--|--|--|--|--|--|--|--|--|--|

| BUILDING DIMENSIONS | | | | | | | | | | | | | |
|--|--|--|--|--|--|--|--|--|--|--|--|--|--|
| BAS= W15 PTO= N12 W9 S12 E9\$ FOP= W9 S18 E9 N18\$ S18 W9 N8 FOP= N18 W22 S8 W15 S10 E37\$ W37 S46 E16 FOP= S1E4 N5 W4 S4\$ N4 E4 S4 E13 N2 E5 BAS= S10 E21 BAS= E22 BAS= S2 E27 N25 FCP= N28 FGR= N24 W27 S24 E27\$ W24 FST= W3 S24 E3 N24\$ S24 W3 S4 E27\$ W27 S23\$ N21 W22 S21\$ N21 W21 S11\$ N11 E21 N11 E2 N32\$ PTR= N30 UUS= N12 W8 S12 E8\$ S30\$. | | | | | | | | | | | | | |