

COMM SW COR OF SE1/4 OF SE1/4,  
 RUN E 908.45 FT TO POB, NORTH  
 1327.22 FT TO N LINE OF SE1/4

NORRIS RONALD E/NORRIS BARBARA JEAN  
 268 NW KING CT  
 LAKE CITY, FL 32055

**2026**

29-1S-17-04599-000  

BUILDING CHARACTERISTICS		CONSTRUCTION	
ELEMENT	CD		
Exterior Wall	19	COMMON BRK	100
Roof Structur	03	GABLE/HIP	100
Roof Cover	14	PREFIN MT	100
Interior Wall	05	DRYWALL	100
Interior Floor	14	CARPET	90
Interior Floor	06	VINYL ASB	10
Air Condition	03	CENTRAL	100
Heating Type	04	AIR DUCTED	100
Bedrooms		3	100
Bathrooms		2.5	100
Frame	01	NONE	100
Stories	2.	2.	100
Architectual Units	05	CONV	100
Condition Adj	03	0	100
Kitchen Adjus	01	01	100
Quality	05	05	
DOR CODE	5000 IMPROVED AG		
MAP NUM		MKT AREA	03
NEIGHBORHOOD/LOC	29117.00 1.00/		
AREA TYPE	TOTAL GROSS AREA	PCT OF BASE	YEAR
BAS	858	100	
FSP	225	40	
FUS	1,109	100	
UCP	437	20	
UOP	225	20	
UOP	437	20	
TOTALS	3,291		

MARKET ADJUSTMENTS												
TYPE	MDL	EFF. AREA	TOT ADJ PTS	EFF. BASE RATE	REPL. COST NEW	AYB	EYB	ECON	FNCT	NORM	% COND	
1	SINGLE FAM	100%	- 2021		Heated Area: 1967					HX Base Yr 2021		

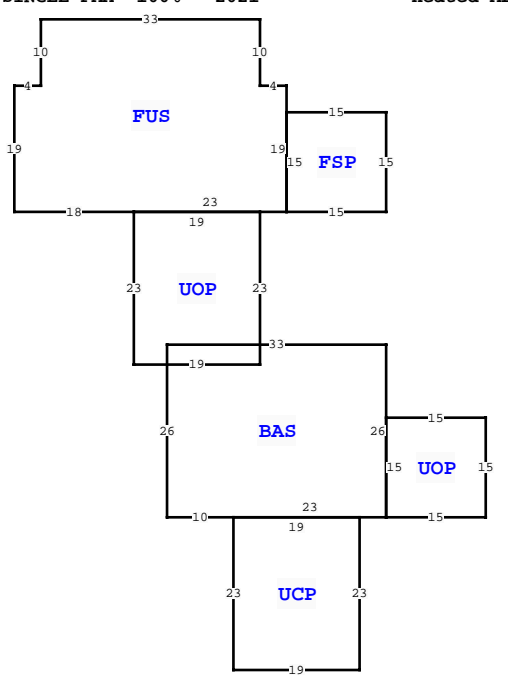

COLUMBIA COUNTY PROPERTY			
VALUATION SUMMARY			PAGE 1 of 1
VALUATION BY			STANDARD
Tax Group: 3	Tax Dist:		
BUILDING MARKET VALUE			208,418
TOTAL MARKET OB/XF VALUE			28,754
TOTAL LAND VALUE - MARKET			83,395
TOTAL MARKET VALUE			246,357
SOH/AGL Deduction			73,087
ASSESSED VALUE			173,270
TOTAL EXEMPTION VALUE	HX HB		51,411
BASE TAXABLE VALUE			121,859
TOTAL JUST VALUE			320,567
NCON VALUE			0
INCOME VALUE			
PREVIOUS YEAR MKT VALUE			315,150
XFOB:1:1: HORTON MH			
PERMIT NUM	DESCRIPTION	AMT	ISSUED

SALES DATA						
OFF RECORD Number	DATE	TYPE INST	Q / U	V / I	RSN CD	SALE PRICE
1419/1513	9/10/2020	WD	U	I	30	100
GRANTOR: CHRISTINE NORRIS						
GRANTEE: RONALD E & BARBARA						
1283/0697	7/18/2014	WD	U	I	14	100
GRANTOR: CHRISTINE & EDWARD NO						
GRANTEE: JOSEPH E & CHRISTIN						

EXTRA FEATURES												
L N	OB/XF CODE	DESCRIPTION	BLD CAP	L	W	UNITS	UT	Adj R	ADJ UNIT PRICE	ORIG COND	YEAR ON	YEAR ACTUAL
1	0190	FPLC PF	0	100	0	0	UT	1,200.00	1,200.00	100	2010	2010
2	0294	SHED WOOD/	0	100	0	0	UT	0.00	0.00	100	2010	2010
3	0120	CLFENCE 4	0	100	0	0	UT	0.00	0.00	100	2010	2010
4	0281	POOL R/FIB	0	100	16	32	UT	65.00	65.00	100	2010	2010
5	0294	SHED WOOD/	0	100	16	12	UT	10.00	10.00	60	2010	2010
6	0020	BARN,FR	0	100	24	30	UT	10.00	10.00	60	2010	2010

TOTAL OB/XF												
28,754												
L N	USE CODE	CLS	LAND USE DESCRIPTION	CAP	R D	LOC ZONE	FRONT	DEPTH	TOT LND UTS	UNIT TYPE	DPTH FACT	% COND
1	0100	C	SFR	100		A-1	0.00	0.00	1.00	AC	1.00	1.00
2	5700	A	TIMBER 4	0		A-1	0.00	0.00	11.83	AC	1.00	1.00
3	9910	M	MKT.VAL.AG	0		A-1	0.00	0.00	11.83	AC	1.00	1.00

BUILDING NOTES						
BLD DATE						
XF DATE						
INC DATE						
LGL DATE						
LAND DATE						
AG DATE						
05/12/2026 MLU						

BUILDING DIMENSIONS												
BAS= W33 S26 E10 UCP= S23 E19 N23 W19\$ E23 UOP= E15 N15 W15 S15\$ N26\$ PTR=N20 FSP= N15 W15 S15 FUS= N19 W4 N10 W33 S10W4 S19 E18 UOP= S23 E19 N23 W19\$ E23\$ E15\$ S20\$.												

LAND DESCRIPTION												
L N	USE CODE	CLS	LAND USE DESCRIPTION	CAP	R D	LOC ZONE	FRONT	DEPTH	TOT LND UTS	UNIT TYPE	DPTH FACT	% COND
1	0100	C	SFR	100		A-1	0.00	0.00	1.00	AC	1.00	1.00
2	5700	A	TIMBER 4	0		A-1	0.00	0.00	11.83	AC	1.00	1.00
3	9910	M	MKT.VAL.AG	0		A-1	0.00	0.00	11.83	AC	1.00	1.00