

COMM NW COR, RUN S 76.28 FT TO S  
E ALONG R/W 297.26 FT FOR POB, C  
FT, S 614.07 FT, W 412.19 FT, N

COLEMAN JOHN A/COLEMAN LOUISE E  
4222 SW CR 242  
LAKE CITY, FL 32024-9815

**2026**

28-4S-16-03234-000  

BUILDING CHARACTERISTICS		CONSTRUCTION	
ELEMENT	CD		
Exterior Wall	19	COMMON BRK	100
Roof Structur	03	GABLE/HIP	100
Roof Cover	03	COMP SHNGL	100
Interior Wall	05	DRYWALL	100
Interior Floor	14	CARPET	90
Interior Floor	06	VINYL ASB	10
Air Condition	03	CENTRAL	100
Heating Type	04	AIR DUCTED	100
Bedrooms		3	100
Bathrooms		2.5	100
Frame	01	NONE	100
Stories	1.	1.	100
Architectual	05	CONV	100
Units		0	100
Condition Adj	03	03	100
Kitchen Adjus	01	01	100
Quality	05	05	
DOR CODE	0100	SINGLE FAMILY	
MAP NUM		MKT AREA	01
NEIGHBORHOOD/LOC	28416.00	1.00/	
AREA TYPE	TOTAL GROSS AREA	PCT OF BASE	YEAR
BAS	2,000	100	
FGR	572	55	
FOP	108	30	
FSP	256	40	
FST	160	55	
TOTALS	3,096		

MARKET ADJUSTMENTS											
TYPE	MDL	EFF. AREA	TOT ADJ PTS	EFF. BASE RATE	REPL. COST NEW	AYB	EYB	ECON	FNCT	NORM	% COND
1	SINGLE FAM	100%	- 1997								
				Heated Area: 2000			HX Base Yr 1997				

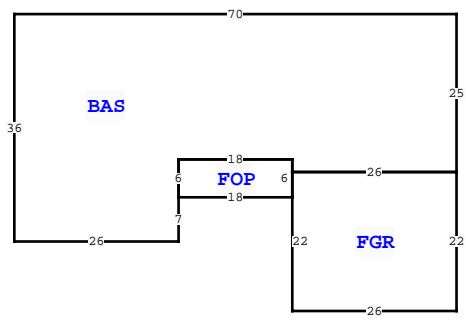
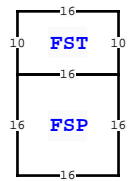

COLUMBIA COUNTY PROPERTY		PAGE 1 of 1	3
VALUATION SUMMARY			
VALUATION BY		STANDARD	
Tax Group: 3	Tax Dist:		
BUILDING MARKET VALUE		209,050	
TOTAL MARKET OB/XF VALUE		8,602	
TOTAL LAND VALUE - MARKET		78,900	
TOTAL MARKET VALUE		296,552	
SOH/AGL Deduction		111,950	
ASSESSED VALUE		184,602	
TOTAL EXEMPTION VALUE	HX HB VX 13	184,602	
BASE TAXABLE VALUE		0	
TOTAL JUST VALUE		296,552	
NCON VALUE		0	
INCOME VALUE			
PREVIOUS YEAR MKT VALUE		288,662	

PERMIT NUM	DESCRIPTION	AMT	ISSUED

SALES DATA						
OFF RECORD Number	DATE	TYPE INST	Q / U	V / I	RSN CD	SALE PRICE
0832/0740	12/12/1996	WD	Q	I		135,000
GRANTOR: RALPH & CAROLYN NORRI						
GRANTEE: JOHN A & LOUISE COL						

EXTRA FEATURES																
L N	OB/XF CODE	DESCRIPTION	BLD CAP	L	W	UNITS	UT	Adj R	ADJ UNIT PRICE	ORIG COND	YEAR ON	YEAR ACTUAL	Q	% COND	OB/XF MKT VALUE	NOTES
1	0166	CONC,PAVMT	0	100	0	0	1.00	UT	0.00	100	1988	1988	3	100	900	
2	0180	FPLC 1STRY	0	100	0	0	1.00	UT	2,000.00	100	1988	1988	3	100	2,000	
3	0020	BARN,FR	0	100	24	36	864.00	UT	11.00	60	1993	1993	3	60	5,702	
TOTALS															8,602	

BUILDING NOTES											

BUILDING DIMENSIONS											
BAS= W70 S36 E26 N7 FOP= E18N6 W18 S6\$ N6 E18 S2 FGR= S22 E26 N22 W26\$ E26 N25\$ PTR=N30 FSP= N16 FST= N10 W16 S10 E16\$ W16 S16 E16\$ S30\$.											

LAND DESCRIPTION												TOTAL OB/XF												
L N	USE CODE	CLS	LAND USE DESCRIPTION	CAP	R D	LOC ZONE	FRONT	DEPTH	TOT LND UTS	UNIT TYPE	D T	DPH FACT	% COND	TOT ADJ	UNIT PRICE	ADJ UNIT PRICE	LAND VALUE	OTHER ADJUSTMENTS AND NOTES	YEAR	DENSITY	DECL	FRZ	YR	CONSRV
1	0100	C	SFR	100		A-1	0.00	0.00	7.89	AC		1.00	1.00	1.00	10,000.00	10,000.00	78,900							