

BEG SW COR OF NW1/4 OF NE1/4, RU
E 200 FT, N 100 FT, E 634.68 FT,
E 487.25 FT TO E LINE OF NW1/4 O

DOVNER GERALD ALAN/DOVNER ANDREA
575 SW WEATHERBY PLACE
LAKE CITY, FL 32024

2026

26-5S-15-00480-001



ELEMENT	CD	CONSTRUCTION
Exterior Wall	17	MSNRY STUC 100
Roof Structur	03	GABLE/HIP 100
Roof Cover	12	MODULAR MT 100
Interior Wall	05	DRYWALL 100
Interior Floo	15	HARDTILE 100
Air Condition	03	CENTRAL 100
Heating Type	04	AIR DUCTED 100
Bedrooms		4 100
Bathrooms		4 100
Frame	01	NONE 100
Stories	1.5	1.5 100
Architctural	05	CONV 100
Units		0 100
Condition Adj	03	03 100
Kitchen Adjus	01	01 100

TYPE	MDL	EFF. AREA	TOT ADJ PTS	EFF. BASE RATE	REPL. COST NEW	AYB	EYB	ECON	FNCT	NORM	% COND
0100	01	3,032	140.0438	156.85	475,569	2013	2013	0	0	12.00	88.00

1 SINGLE FAM 100% - 2025 Heated Area: 2820 HX Base Yr 2025

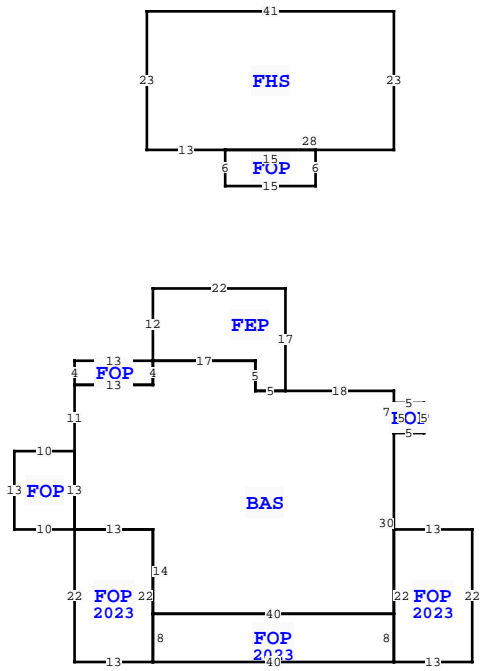

AREA TYPE	TOTAL GROSS AREA	PCT OF BASE	YEAR	TOT ADJ AREA	SUBAREA MARKET VALUE
BAS	1,877	100		1,877	259,078
FEP	289	80		231	31,884
FHS	943	60		566	78,124
FOP	25	30		8	1,104
FOP	52	30		16	2,209
FOP	90	30		27	3,727
FOP	130	30		39	5,383
FOP	286	30	2023	86	11,870
FOP	286	30	2023	86	11,870
FOP	320	30	2023	96	13,251
TOTALS	4,298			3,032	418,501

L N	OB/XF CODE	DESCRIPTION	BLD CAP	L	W	UNITS	UT	Adj R	ADJ UNIT PRICE	ORIG COND	YEAR ON	YEAR ACTUAL	Q	% COND	OB/XF MKT VALUE	NOTES
1	0190	FPLC PF	0	100	0	0	0	1.00	UT 1,200.00	1,200.00	100	1993	1993	3	100	1,200
2	0020	BARN,FR	0	100	0	0	0	1.00	UT 0.00	0.00	100	1993	1993	3	100	1,820
3	0031	BARN,MT AE	0	100	0	0	0	1.00	UT 0.00	0.00	100	1993	1993	3	100	1,400
4	0031	BARN,MT AE	0	100	0	0	0	1.00	UT 0.00	0.00	100	2013	2013	3	100	2,100
5	0169	FENCE/WOOD	0	100	0	0	0	1.00	UT 0.00	0.00	100	2016	2016	3	100	300
6	0252	LEAN-TO W/	0	100	0	0	0	1.00	UT 0.00	0.00	100	2016	2016	3	100	200
7	0166	CONC,PAVMT	0	100	0	0	0	1.00	UT 0.00	0.00	100	2016	2016	3	100	1,600
8	0104	GENERATOR	0	100	0	0	0	1.00	UT 6,000.00	6,000.00	100	2025	2024		90	5,400

575 SW WEATHERBY PL, LAKE CITY

BLD DATE	LGL DATE	05/07/2026	MLU
XF DATE	LAND DATE		
INC DATE	AG DATE		

VALUATION SUMMARY		PAGE 1 of 1	3
VALUATION BY		STANDARD	
Tax Group: 3	Tax Dist:		
BUILDING MARKET VALUE		418,501	
TOTAL MARKET OB/XF VALUE		14,020	
TOTAL LAND VALUE - MARKET		132,570	
TOTAL MARKET VALUE		565,091	
SOH/AGL Deduction		81,010	
ASSESSED VALUE		484,081	
TOTAL EXEMPTION VALUE	HX HB	51,411	
BASE TAXABLE VALUE		432,670	
TOTAL JUST VALUE		565,091	
NCON VALUE		0	
INCOME VALUE			
PREVIOUS YEAR MKT VALUE		474,603	

PERMIT NUM	DESCRIPTION	AMT	ISSUED
000049853	Electrical Servic	0	05/20/2024
30620	REMODEL	979	11/27/2012

SALES DATA						
OFF RECORD Number	DATE	TYPE INST	Q / U	V / I	RSN CD	SALE PRICE
1514/752	5/06/2024	WD	U	I	37	772,500

GRANTOR: SCHNABEL DANIEL K
GRANTEE: DOVNER GERALD ALAN
1259/2174 8/02/2013 QC U I 11 100
GRANTOR: DANIEL K SCHNABEL
GRANTEE: DANIEL K & LISA SCH

BUILDING NOTES	
BAS=[ORIG=0,0] W18 W5 N5 W17 S4 W13 S11 S13 E13 S14 E40 N30 N7 \$	
FHS=[ORIG=0,-40] N23 W41 S23 E13 E28 \$	
FOP=[YR=2023;ORIG=-40,37] S8 E40 N8 W40 \$	
FEP=[ORIG=-18,0] N17 W22 S12 E17 S5 E5 \$	
FOP=[YR=2023;ORIG=-40,23] S22 W13 N22 E13 \$	
FOP=[YR=2023;ORIG=0,23] E13 S22 W13 N22 \$	
FOP=[ORIG=-53,10] W10 S13 E10 N13 \$	
FOP=[ORIG=-28,-40] S6 E15 N6 W15 \$	
FOP=[ORIG=-40,-5] W13 S4 E13 N4 \$	
FOP=[ORIG=0,7] E5 N5 W5 S5 \$	

BUILDING DIMENSIONS	
BAS=[ORIG=0,0] W18 W5 N5 W17 S4 W13 S11 S13 E13 S14 E40 N30 N7 \$	
FHS=[ORIG=0,-40] N23 W41 S23 E13 E28 \$	
FOP=[YR=2023;ORIG=-40,37] S8 E40 N8 W40 \$	
FEP=[ORIG=-18,0] N17 W22 S12 E17 S5 E5 \$	
FOP=[YR=2023;ORIG=-40,23] S22 W13 N22 E13 \$	
FOP=[YR=2023;ORIG=0,23] E13 S22 W13 N22 \$	
FOP=[ORIG=-53,10] W10 S13 E10 N13 \$	
FOP=[ORIG=-28,-40] S6 E15 N6 W15 \$	
FOP=[ORIG=-40,-5] W13 S4 E13 N4 \$	
FOP=[ORIG=0,7] E5 N5 W5 S5 \$	

LAND DESCRIPTION		TOTAL OB/XF 14,020																						
L N	USE CODE	CLS	LAND USE DESCRIPTION	CAP	R D	LOC ZONE	FRONT	DEPTH	TOT LND UTS	UNIT TYPE	D T	DPTH FACT	% COND	TOT ADJ	UNIT PRICE	ADJ UNIT PRICE	LAND VALUE	OTHER ADJUSTMENTS AND NOTES	YEAR	DENSITY	DECL	FRZ	YR	CONSRV
1	0100	C	SFR	100		A-1	0.00	0.00	1.00	AC		1.00	1.00	1.00	9,000.00	9,000.00	9,000							
2	9900	C	AC NON-AG	100					13.73	AC		1.00	1.00	1.00	9,000.00	9,000.00	123,570							