

LOT 1 LAKE CITY AIRPARK S/D EX B  
 RUN SW 100 FT, SE 285 FT, N 125  
 201.25 FT TO POB & LOTS 2 & 19 L

TAYLOR SPENCER HOWARD/TAYLOR SHANNA LEE  
 307 SW CIRRUS DR  
 LAKE CITY, FL 32025

**2026**

22-5S-17-09322-002

ELEMENT	CD	CONSTRUCTION
Exterior Wall	19	COMMON BRK 100
Roof Structur	03	GABLE/HIP 100
Roof Cover	03	COMP SHNGL 100
Interior Wall	05	DRYWALL 100
Interior Floo	14	CARPET 80
Interior Floo	08	SHT VINYL 20
Air Condition	03	CENTRAL 100
Heating Type	04	AIR DUCTED 100
Bedrooms		3 100
Bathrooms		2.5 100
Frame	01	NONE 100
Stories	1.1	1. 100
Architectual	05	CONV 100
Units		0 100
Condition Adj	02	02 100
Kitchen Adjus	01	01 100

MARKET ADJUSTMENTS												
TYPE	MDL	EFF. AREA	TOT ADJ PTS	EFF. BASE RATE	REPL. COST NEW	AYB	EYB	ECON	FNCT	NORM	% COND	
0100	01	5,736	95.4180	106.87	613,006	1988	1988	0	0	0 35.00	65.00	
1 SINGLE FAM 100% - 2017 Heated Area: 3050 HX Base Yr 2017												

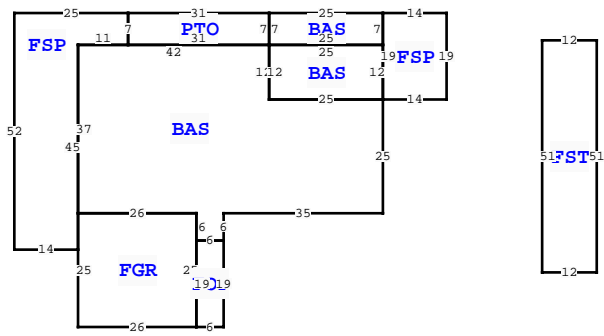
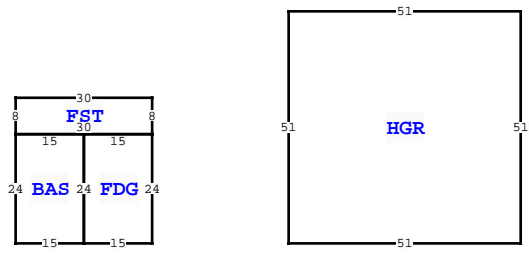

Quality	05	05			
DOR CODE	0100	SINGLE FAMILY			
MAP NUM		MKT AREA 02			
NEIGHBORHOOD/LOC	22517.020	1.00/			
AREA TYPE	TOTAL GROSS AREA	PCT OF BASE	YEAR	TOT ADJ AREA	SUBAREA MARKET VALUE
BAS	175	100		175	12,156
BAS	300	100		300	20,840
BAS	360	100		360	25,007
BAS	2,215	100		2,215	153,866
FDG	360	60		216	15,005
FGR	650	55		358	24,868
FOP	114	30		34	2,362
FSP	266	40		106	7,363
FSP	805	40		322	22,368
FST	240	55		132	9,170
TOTALS	8,915			5,736	398,454

\*\* This building has 13 Sub-Areas

BLD DATE	LGL DATE	05/12/2026	MLU
XF DATE	LAND DATE		
INC DATE	AG DATE		

307 SW CIRRUS DR, LAKE CITY

L N	OB/XF CODE	DESCRIPTION	BLD	CAP	L	W	UNITS	UT	Adj R	ADJ UNIT PRICE	ORIG COND	YEAR ON	YEAR ACTUAL	Q	% COND	OB/XF MKT VALUE	NOTES
1	0166	CONC, PAVMT	0	100	0	0	1.00	UT	0.00	0.00	100	1999	1999	3	100	1,000	
2	0280	POOL R/CON	0	100	18	38	684.00	UT	35.00	35.00	100	1999	1999	3	40	9,576	
3	0282	POOL ENCL	0	100	47	52	2,444.00	UT	7.50	7.50	100	1999	1999	3	40	7,332	
4	0166	CONC, PAVMT	0	100	0	0	1,760.00	UT	1.50	1.50	100	1999	1999	3	100	2,640	
5	0166	CONC, PAVMT	0	100	0	0	6,465.00	UT	1.50	1.50	100	1999	1999	3	100	9,698	
6	0190	FPLC PF	0	100	0	0	1.00	UT	1,200.00	1,200.00	100	2012	2012	3	100	1,200	
7	0166	CONC, PAVMT	0	0	49	50	1.00	UT	0.00	0.00	100	0	0	3	100	1,000	
8	0006	AIRPL HGR	0	100	0	0	1.00	UT	112,500.00	112,500.00	100	2024	2023		100	112,500	

COLUMBIA COUNTY PROPERTY				PAGE 1 of 1	3
VALUATION SUMMARY				STANDARD	
VALUATION BY				Tax Group: 3 Tax Dist:	
BUILDING MARKET VALUE				398,454	
TOTAL MARKET OB/XF VALUE				144,946	
TOTAL LAND VALUE - MARKET				157,500	
TOTAL MARKET VALUE				700,900	
SOH/AGL Deduction				183,309	
ASSESSED VALUE				517,591	
TOTAL EXEMPTION VALUE				HX HB 51,411	
BASE TAXABLE VALUE				466,180	
TOTAL JUST VALUE				700,900	
NCON VALUE				0	
INCOME VALUE				0	
PREVIOUS YEAR MKT VALUE				658,900	
PRMT:1:1: AIRPLANE HANGER					
LAND:1:1: 4.05 AC					

PERMIT NUM	DESCRIPTION	AMT	ISSUED
000054497	Roof Replacement	17,500	11/17/2025
000046229	Storage Building	153,000	01/10/2023
14827	GARAGE	200	12/09/1998
14821	POOL	235	12/07/1998

SALES DATA						
OFF RECORD Number	DATE	TYPE INST	Q / U	V / I	RSN CD	SALE PRICE
1449/1424	9/24/2021	WD Q	Q	V	04	68,000
GRANTOR: CARNEVALE FAMILY LIVI						
GRANTEE: TAYLOR SPENCER						
1349/0490	11/30/2017	WD U	U	I	16	52,500
GRANTOR: ROGER A DICK & MARIAN						
GRANTEE: SPENCER HOWARD TAYL						

BUILDING NOTES	

BUILDING DIMENSIONS	
BAS= W42 S37 FGR= S25 E26 N25 W26\$ E26 S6 FOP= S19 E6 N19 W6\$ E6 N6 E35 N25 FSP= E14 N19 W14 S19 \$ BAS= N12 W25 S12 E25\$ W25 N12 BAS= E25 N7 W25 PTO= W31 FSP= W25 S52 E14 N45 E11 N7\$ S7 E31 N7\$ S7\$ PTR=N30 FDG= N24 FST= N8 W30 S8 E30\$ W15 BAS= W15 S24 E15 N24\$ S24 E15\$ S30\$ PTR= N30 E30 HGR= E51 N51 W51 S51\$ S30 W30\$ PTR= E60 S50 FST= E12 N51 W12 S51\$ W60 N50 \$.	

LAND DESCRIPTION										TOTAL OB/XF										144,946				
L N	USE CODE	CLS	LAND USE DESCRIPTION	CAP	R D	LOC ZONE	FRONT	DEPTH	TOT LND UTS	UNIT TYPE	D T	DPH FACT	% COND	TOT ADJ	UNIT PRICE	ADJ UNIT PRICE	LAND VALUE	OTHER ADJUSTMENTS AND NOTES	YEAR	DENSITY	DECL	FRZ	YR	CONSRV
1	0100	C	SFR	100		RSF-1	0.00	0.00	1.00	LT		1.00	1.00	0.70	75,000.00	52,500.00	52,500							
2	0000	C	VAC RES	0		RSF-1	0.00	0.00	1.00	LT		1.00	1.00	0.70	75,000.00	52,500.00	52,500							
3	0700	C	MISC RES	100		RSF-1	0.00	0.00	1.00	LT		1.00	1.00	0.70	75,000.00	52,500.00	52,500							