

BUILDING CHARACTERISTICS		CONSTRUCTION	
ELEMENT	CD		
Exterior Wall	32	HARDIE BRD	100
Roof Structur	08	IRREGULAR	100
Roof Cover	03	COMP SHNGL	100
Interior Wall	05	DRYWALL	100
Interior Floo	08	SHT VINYL	80
Interior Floo	15	HARDTILE	20
Air Condition	03	CENTRAL	100
Heating Type	04	AIR DUCTED	100
Bedrooms		4	100
Bathrooms		5	100
Frame	02	WOOD FRAME	100
Stories	1.5	1.5	100
Architectual	05	CONV	100
Units		0	100
Quality	07	07	
DOR CODE	0100	SINGLE FAMILY	
MAP NUM		MKT AREA	06
NEIGHBORHOOD/LOC	22316.030	1.00/	
AREA TYPE	TOTAL GROSS AREA	PCT OF BASE	YEAR
BAS	3,281	100	
FGR	827	55	
FHS	484	60	
FOP	126	30	
FOP	147	30	
FSP	224	40	
TOTALS	5,089		

MARKET ADJUSTMENTS											
TYPE	MDL	EFF. AREA	TOT ADJ PTS	EFF. BASE RATE	REPL. COST NEW	AYB	EYB	ECON	FNCT	NORM	% COND
1	SINGLE FAM	100%	- 2018		601,573	2017	2017	0	0	8.00	92.00
Heated Area: 3765						HX Base Yr 2018					

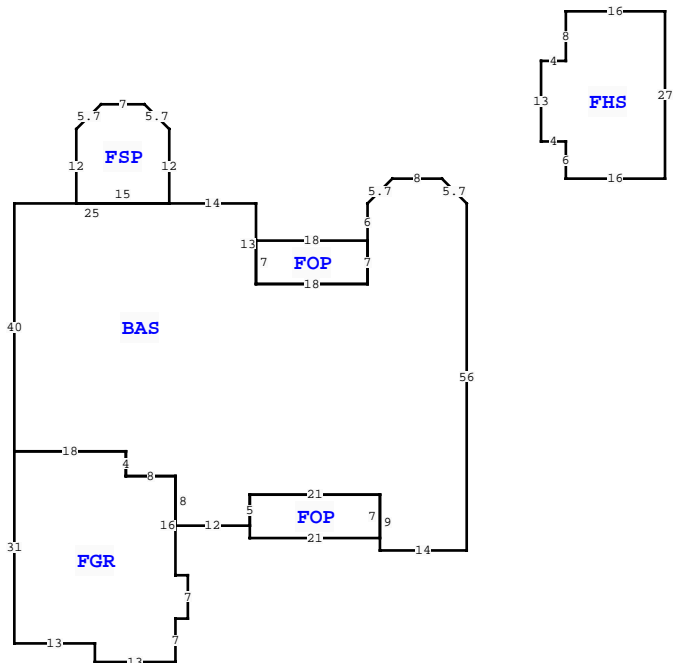

COLUMBIA COUNTY PROPERTY		
VALUATION SUMMARY		PAGE 1 of 1
VALUATION BY	STANDARD	
Tax Group: 2	Tax Dist:	
BUILDING MARKET VALUE	553,447	
TOTAL MARKET OB/XF VALUE	15,800	
TOTAL LAND VALUE - MARKET	57,750	
TOTAL MARKET VALUE	626,997	
SOH/AGL Deduction	201,868	
ASSESSED VALUE	425,129	
TOTAL EXEMPTION VALUE	HX HB 51,411	
BASE TAXABLE VALUE	373,718	
TOTAL JUST VALUE	626,997	
NCON VALUE	0	
INCOME VALUE	0	
PREVIOUS YEAR MKT VALUE	633,313	

PERMIT NUM	DESCRIPTION	AMT	ISSUED
34945	SFR	1,648	02/16/2017

SALES DATA						
OFF RECORD Number	DATE	TYPE INST	Q / U	V / I	RSN CD	SALE PRICE
1314/0621	4/27/2016	WD Q	Q	V	01	37,000

GRANTOR: RUTHIE ROWAN BERNECKE
GRANTEE: BEN & JANE PITCHFORD

BUILDING NOTES	

BUILDING DIMENSIONS	
BAS= W8 D4 L4 S6 FOP= W18 S7 E18 N7\$ S7 W18 N13 W14 FSP= N12 L4 U4 W7 D4 L4 S12 E15\$ W25 S40 FGR= S31 E13 S3 E13 N7 E2 N7 W2 N16 W8 N4 W18\$ E18 S4 E8 S8 E12 FOP= S2 E21 N7 W21 S5\$ N5 E21 S9 E14 N56 L4 U4 \$ PTR= E20 FHS= E16 N27 W16 S8 W4 S13 E4 S6\$ W20\$.	

EXTRA FEATURES																
L N	OB/XF CODE	DESCRIPTION	BLD CAP	L	W	UNITS	UT	Adj R	ADJ UNIT PRICE	ORIG COND	YEAR ON	YEAR ACTUAL	Q	% COND	OB/XF MKT VALUE	NOTES
1	0166	CONC, PAVMT	0	100	0	0	1.00	UT	0.00	100	2018	2018	3	100	5,000	
2	0104	GENERATOR	0	100	0	0	1.00	UT	6,000.00	100	2023	2022		80	4,800	
3	0296	SHED METAL	0	100	0	0	1.00	UT	6,000.00	100	2023	2022		100	6,000	

LAND DESCRIPTION		TOTAL OB/XF																						
L N	USE CODE	CLS	LAND USE DESCRIPTION	CAP	R D	LOC ZONE	FRONT	DEPTH	TOT LND UTS	UNIT TYPE	D T	DPH FACT	% COND	TOT ADJ	UNIT PRICE	ADJ UNIT PRICE	LAND VALUE	OTHER ADJUSTMENTS AND NOTES	YEAR	DENSITY	DECL	FRZ	YR	CONSRV
1	0100	C	SFR	100			0.00	0.00	1.00	LT		1.00	1.00	1.65	35,000.00	57,750.00	57,750							