

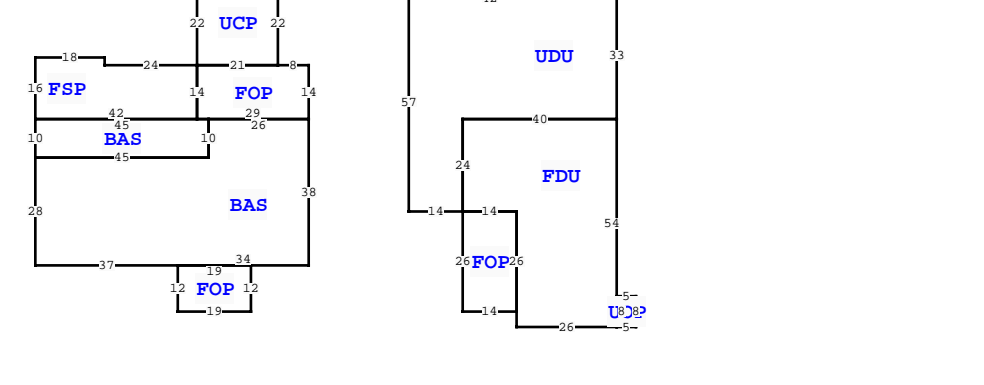

ELEMENT	CD	CONSTRUCTION
Exterior Wall	31	VINYL SID 80
Exterior Wall	18	CEMENT BRK 20
Roof Structur	03	GABLE/HIP 100
Roof Cover	03	COMP SHNGL 100
Interior Wall	05	DRYWALL 100
Interior Floor	14	CARPET 90
Interior Floor	06	VINYL ASB 10
Air Condition	03	CENTRAL 100
Heating Type	04	AIR DUCTED 100
Bedrooms		3 100
Bathrooms		2 100
Frame	01	NONE 100
Stories	1.	1. 100
Architectual	05	CONV 100
Units		0 100
Condition Adj	03	03 100
Kitchen Adjus	01	01 100

MARKET ADJUSTMENTS												
TYPE	MDL	EFF. AREA	TOT ADJ PTS	EFF. BASE RATE	REPL. COST NEW	AYB	EYB	ECON	FNCT	NORM	% COND	
0100	01	6,819	98.3250	110.12	750,908	1962	1962	0	0	35.00	65.00	

COLUMBIA COUNTY PROPERTY			
VALUATION SUMMARY			PAGE 1 of 2
VALUATION BY			STANDARD
Tax Group: 3		Tax Dist:	
BUILDING MARKET VALUE			505,881
TOTAL MARKET OB/XF VALUE			48,380
TOTAL LAND VALUE - MARKET			34,520
TOTAL MARKET VALUE			588,781
SOH/AGL Deduction			374,401
ASSESSED VALUE			214,380
TOTAL EXEMPTION VALUE			51,411
BASE TAXABLE VALUE			162,969
TOTAL JUST VALUE			588,781
NCON VALUE			0
INCOME VALUE			
PREVIOUS YEAR MKT VALUE			582,260



Quality		DOR CODE			
05	05	0100	SINGLE FAMILY		
MAP NUM		MKT AREA			
		03			
NEIGHBORHOOD/LOC					
22216.030 1.00/					
AREA TYPE	TOTAL GROSS AREA	PCT OF BASE	YEAR	TOT ADJ AREA	SUBAREA MARKET VALUE
BAS	450	100		450	32,210
BAS	2,248	100		2,248	160,908
FDU	1,740	60		1,044	74,727
FOP	228	30		68	4,867
FOP	364	30		109	7,802
FOP	406	30		122	8,733
FSP	624	40		250	17,895
UCP	462	20		92	6,585
UDU	2,118	55		1,165	83,389
UDU	2,296	55		1,263	90,403
TOTALS				10,976	488,090

PERMIT NUM	DESCRIPTION	AMT	ISSUED
11863	POOL	90	11/15/1996

SALES DATA						
OFF RECORD Number	DATE	TYPE INST	Q / U	V / I	RSN CD	SALE PRICE
1142/0534	1/31/2008	WD	Q	I	01	27,500

** This building has 11 Sub-Areas
 8770 NW US HIGHWAY 41 , LAKE CITY

BLD DATE	LGL DATE
XF DATE	LAND DATE
INC DATE	AG DATE
	05/11/2026 MLU

EXTRA FEATURES																	
L N	OB/XF CODE	DESCRIPTION	BLD	CAP	L	W	UNITS	UT	Adj R	ADJ UNIT PRICE	ORIG COND	YEAR ON	YEAR ACTUAL	Q	% COND	OB/XF MKT VALUE	NOTES
1	0260	PAVEMENT-A	0	100	0	0	1.00	UT	0.00	0.00	100	0	0	3	100	4,600	
2	0190	FPLC PF	0	100	0	0	1.00	UT	1,200.00	1,200.00	100	0	0	3	100	1,200	
3	0280	POOL R/CON	0	100	32	16	512.00	UT	70.00	70.00	100	1996	1996	3	40	14,336	
4	9945	Well/Sept	0	100	0	0	1.00	UT	7,000.00	7,000.00	100			3	100	7,000	
5	0166	CONC, PAVMT	0	100	5	10	50.00	UT	1.50	1.50	100	1996	1996	3	100	75	
6	0120	CLFENCE 4	0	100	0	0	490.00	UT	7.50	7.50	100	2008	2008	3	100	3,675	
7	0282	POOL ENCL	0	100	46	44	2,024.00	UT	15.00	15.00	100	2008	2008	3	40	12,144	
8	0060	CARPORT F	0	100	20	25	500.00	UT	5.00	5.00	100	2008	2008	3	100	2,500	
9	0070	CARPORT UF	0	100	0	0	1.00	UT	0.00	0.00	100	2008	2008	3	100	900	
10	0070	CARPORT UF	0	100	0	0	1.00	UT	0.00	0.00	100	2008	2008	3	100	500	

GRANTOR: JONATHAN WILLIAMS (HE			
GRANTEE: DONNIE & CHERYL SKI			
1140/0864	1/09/2008	WD	Q I 03
GRANTOR: SPENCER HARPER (HEIR)			
GRANTEE: DONNIE & CHERYL SKI			

BUILDING NOTES												
BUILDING DIMENSIONS												
FOP= N14 W8 UCP= N22 W21 S22E21\$ W21 FSP= W24 N2 W18 S16 E42 N14\$ S14 E29\$ BAS= W26 BAS= W45 S10 E45 N10\$ S10 W45S28 E37 FOP= S12 E19 N12 W19\$E34 N38\$ PTR= E40 FDU= E40 S54 UOP= E5 N8 W5 S8\$ W26 N4 FOP= W14 N26 E14 S26\$ N26 W14 UDU= N24 E40 N33 W12 UDU= N82 W28 S82 E28\$ W42 S57 E14\$ N24\$ W40 \$.												

LAND DESCRIPTION													TOTAL OB/XF												
L N	USE CODE	CLS	LAND USE DESCRIPTION	CAP	R D	LOC ZONE	FRONT	DEPTH	TOT LND UTS	UNIT TYPE	D T	DPH FACT	% COND	TOT ADJ	UNIT PRICE	ADJ UNIT PRICE	LAND VALUE	OTHER ADJUSTMENTS AND NOTES	YEAR	DENSITY	DECL	FRZ	YR	CONSRV	
1	0100	C	SFR	100		00	0.00	0.00	1.75	AC		1.00	1.00	1.00	9,000.00	9,000.00	15,750								
2	0102	C	SFR/MH	100		00	0.00	0.00	1.63	AC		1.00	1.00	0.85	9,000.00	7,650.00	12,470								
3	0000	C	VAC RES	100		00	110.00	277.00	0.70	AC		1.00	1.00	1.00	9,000.00	9,000.00	6,300								

COMM SW COR OF NW1/4 OF SW1/4,
 RUN NE 448.24 FT, CONT NE 248
 FT FOR POB, CONT NE 279 FT TO

SKIPPER DONNIE E/SKIPPER LINDA C
 8770 NW US HWY 41
 LAKE CITY, FL 32055

2026

22-2S-16-01703-001

BUILDING CHARACTERISTICS		CONSTRUCTION	
ELEMENT	CD		
Exterior Wall	01	MINIMUM	100
Roof Structur	03	GABLE/HIP	100
Roof Cover	01	MINIMUM	100
Interior Wall	04	PLYWOOD	100
Interior Floo	14	CARPET	90
Interior Floo	08	SHT VINYL	10
Air Condition	03	CENTRAL	100
Heating Type	04	AIR DUCTED	100
Bedrooms		2	100
Bathrooms		2	100
Stories	1.	1.	100
Architectual	01	CONV	100
Units		0	100
Condition Adj	02	02	100
Kitchen Adjus	01	01	100
Quality	02	02	
DOR CODE	0100	SINGLE FAMILY	
MAP NUM		MKT AREA	03
NEIGHBORHOOD/LOC	22216.030	1.00/	
AREA TYPE	TOTAL GROSS AREA	PCT OF BASE	YEAR
BAS	108	100	
BAS	732	100	
FSP	160	40	
FSP	208	40	
FSP	320	40	
TOTALS	1,528		

MARKET ADJUSTMENTS													
TYPE	MDL	EFF. AREA	TOT ADJ PTS	EFF. BASE RATE	REPL. COST NEW	AYB	EYB	ECON	FNCT	NORM	% COND		
0800	02	1,115	66.4785	39.89	44,477	1972	1972	0	0	60.00	40.00		
2 MOBILE HME 0% - 0 Heated Area: 840 HX Base Yr													

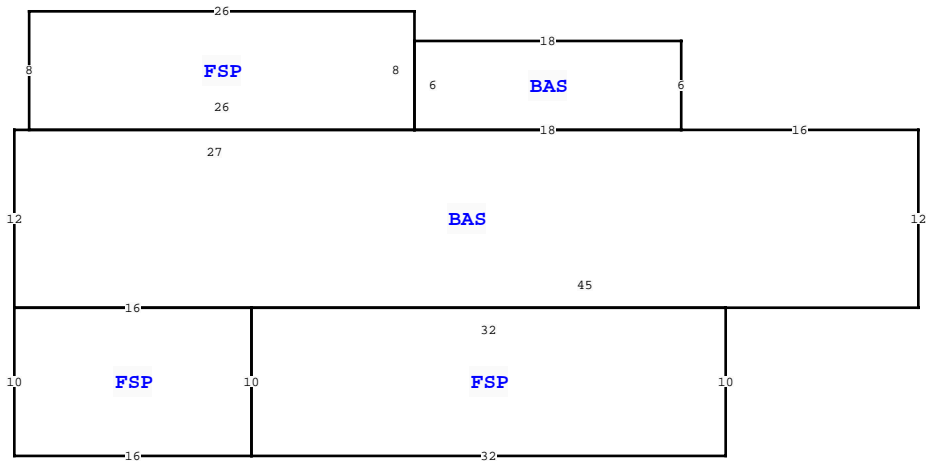

EXTRA FEATURES	L N	OB/XF CODE	DESCRIPTION	BLD CAP	L	W	UNITS	UT	Adj R	ADJ UNIT PRICE	ORIG COND	YEAR ON	YEAR ACTUAL	Q	% COND	OB/XF MKT VALUE	NOTES
	11	0070	CARPORT UF	0	100	0	0	0	0.00	0.00	100	2008	2008	3	100	500	
	12	0060	CARPORT F	0	100	18	20	0	2.50	2.50	50	2008	2008	3	50	450	
	13	0166	CONC,PAVMT	0	100	0	0	0	0.00	0.00	100	2008	2008	3	100	500	

TOTAL OB/XF														1,450			
-------------	--	--	--	--	--	--	--	--	--	--	--	--	--	-------	--	--	--

LAND DESCRIPTION																								
L N	USE CODE	CLS	LAND USE DESCRIPTION	CAP	R D	LOC ZONE	FRONT	DEPTH	TOT LND UTS	UNIT TYPE	D T	DPHT FACT	% COND	TOT ADJ	UNIT PRICE	ADJ UNIT PRICE	LAND VALUE	OTHER ADJUSTMENTS AND NOTES	YEAR	DENSITY	DECL	FRZ	YR	CONSRV

TOTAL OB/XF														1,450			
-------------	--	--	--	--	--	--	--	--	--	--	--	--	--	-------	--	--	--

COLUMBIA COUNTY PROPERTY				PAGE 2 of 2	3
VALUATION SUMMARY					
VALUATION BY				STANDARD	
Tax Group: 3				Tax Dist:	
BUILDING MARKET VALUE				505,881	
TOTAL MARKET OB/XF VALUE				48,380	
TOTAL LAND VALUE - MARKET				34,520	
TOTAL MARKET VALUE				588,781	
SOH/AGL Deduction				374,401	
ASSESSED VALUE				214,380	
TOTAL EXEMPTION VALUE				HX HB 51,411	
BASE TAXABLE VALUE				162,969	
TOTAL JUST VALUE				588,781	
NCON VALUE				0	
INCOME VALUE					
PREVIOUS YEAR MKT VALUE				582,260	

PERMIT NUM	DESCRIPTION	AMT	ISSUED

SALES DATA							
OFF RECORD Number	DATE	TYPE INST	Q U	V I	RSN CD	SALE PRICE	
1142/0534	1/31/2008	WD Q	Q	I	01	27,500	
GRANTOR: JONATHAN WILLIAMS (HE)							
GRANTEE: DONNIE & CHERYL SKI							
1140/0864	1/09/2008	WD Q	Q	I	03	12,500	
GRANTOR: SPENCER HARPER (HEIR)							
GRANTEE: DONNIE & CHERYL SKI							

BUILDING NOTES													
----------------	--	--	--	--	--	--	--	--	--	--	--	--	--

BUILDING DIMENSIONS													
BAS= W16 BAS= N6 W18 S6 E18\$ W18 FSP= N8 W26 S8 E26 \$ W27 S12 FSP= S10 E16 N10 W16\$E16 FSP= S10 E32 N10 W32\$ E45N12\$.													