

COMM NE COR OF SEC & RUN W 1719.  
 THENCE W 846.84 FT S 490.55 FT F  
 CONT S 236.34 FT TO POINT OF A C

GIEBEIG B TRENT  
 697 SE HOLLY TERR  
 LAKE CITY, FL 32025

**2026**

21-4S-17-08631-002

ELEMENT	CD	CONSTRUCTION
Exterior Wall	19	COMMON BRK 100
Roof Structur	04	WOOD TRUSS 100
Roof Cover	03	COMP SHNGL 100
Interior Wall	05	DRYWALL 100
Interior Floor	15	HARDTILE 80
Interior Floor	12	HARDWOOD 20
Air Condition	03	CENTRAL 100
Heating Type	04	AIR DUCTED 100
Bedrooms		4 100
Bathrooms		2 100
Frame	02	WOOD FRAME 100
Stories	1.	1. 100
Architectual Units	05	CONV 100
Condition Adj	03	03 100
Kitchen Adjus	01	01 100

MARKET ADJUSTMENTS														
TYPE	MDL	EFF. AREA	TOT ADJ PTS	EFF. BASE RATE	REPL. COST NEW	AYB	EYB	ECON	FNCT	NORM	% COND			
0100	01	4,069	126.9730	142.21	578,652	2006	2006	0	0	0	19.00	81.00		

1 SINGLE FAM 100% - 2008 Heated Area: 2717 HX Base Yr 2008

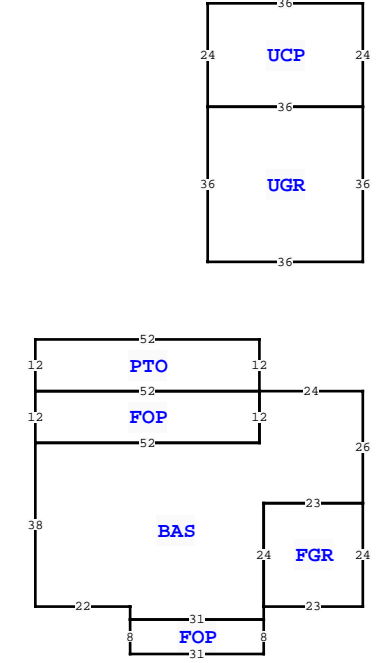

Quality		07 07			
DOR CODE		5000 IMPROVED AG			
MAP NUM		MKT AREA 02			
NEIGHBORHOOD/LOC		21417.00 1.00/			
AREA TYPE	TOTAL GROSS AREA	PCT OF BASE	YEAR	TOT ADJ AREA	SUBAREA MARKET VALUE
BAS	2,717	100		2,717	312,972
FGR	552	55		304	35,018
FOP	248	30		74	8,524
FOP	624	30		187	21,540
PTO	624	5		31	3,571
UCP	864	20		173	19,928
UGR	1,296	45		583	67,155
<b>TOTALS</b>	<b>6,925</b>			<b>4,069</b>	<b>468,708</b>

**EXTRA FEATURES**

L N	OB/XF CODE	DESCRIPTION	BLD CAP	L	W	UNITS	UT	Adj R	ADJ UNIT PRICE	ORIG COND	YEAR ON	YEAR ACTUAL	Q	% COND	OB/XF MKT VALUE	NOTES
1	0166	CONC,PAVMT	0	100	0	2,254.00	UT	3.00	3.00	100	2006	2006	3	100	6,762	

697 SE HOLLY TER, LAKE CITY

BLD DATE	XF DATE	INC DATE	LGL DATE	LAND DATE	AG DATE
				05/06/2026	MLU

COLUMBIA COUNTY PROPERTY			
VALUATION SUMMARY			PAGE 1 of 1
VALUATION BY		STANDARD	
Tax Group: 2		Tax Dist:	
BUILDING MARKET VALUE		468,708	
TOTAL MARKET OB/XF VALUE		6,762	
TOTAL LAND VALUE - MARKET		51,695	
TOTAL MARKET VALUE		488,778	
SOH/AGL Deduction		154,491	
ASSESSED VALUE		334,287	
TOTAL EXEMPTION VALUE		51,411	
BASE TAXABLE VALUE		282,876	
TOTAL JUST VALUE		527,165	
NCON VALUE		0	
INCOME VALUE			
PREVIOUS YEAR MKT VALUE		529,452	

PERMIT NUM	DESCRIPTION	AMT	ISSUED
24192	SFR	791	03/07/2006

**SALES DATA**

OFF RECORD Number	DATE	TYPE INST	Q U	V I	RSN CD	SALE PRICE
1259/1802	7/31/2013	WD	U	V	11	100

GRANTOR: PETER W GIEBEIG  
 GRANTEE: TRENT GIEBEIG

1121/0731	6/01/2007	WD	Q	I	03	100
GRANTOR: TRENT GIEBEIG CONSTRU GRANTEE: B TRENT GIEBEIG						

**BUILDING NOTES**

**BUILDING DIMENSIONS**

BAS= W24 PTO= N12 W52 S12 E52\$ FOP= W52 S12 E52 N12\$ S12 W52 S38 E22 S3 FOP= S8 E31 N8 W31\$ E31 N3 FGR= E23 N24 W23 S24\$ N24 E23 N26\$ PTR= N30 UGR= N36 UCP= N24 W36 S24 E36\$ W36 S36 E36\$ S30\$.

**LAND DESCRIPTION** TOTAL OB/XF 6,762

L N	USE CODE	CLS	LAND USE DESCRIPTION	CAP	R D	LOC ZONE	FRONT	DEPTH	TOT LND UTS	UNIT TYPE	D T	DPH FACT	% COND	TOT ADJ	UNIT PRICE	ADJ UNIT PRICE	LAND VALUE	OTHER ADJUSTMENTS AND NOTES	YEAR	DENSITY	DECL	FRZ	YR	CONSRV
1	0100	C	SFR	100			0.00	0.00	1.00	AC		1.00	1.00	1.00	12,000.00	12,000.00	12,000							
2	6200	A	PASTURE 3	0			0.00	0.00	4.67	AC		1.00	1.00	1.00	280.00	280.00	1,308							
3	9910	M	MKT.VAL.AG	0			0.00	0.00	4.67	AC		1.00	1.00	1.00	8,500.00	8,500.00	39,695							