

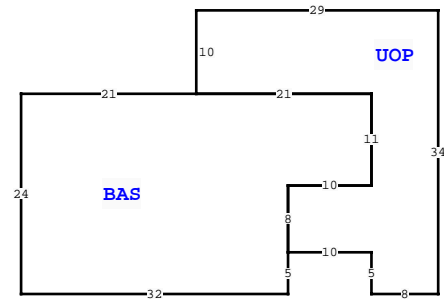

BUILDING CHARACTERISTICS		CONSTRUCTION	
ELEMENT	CD		
Exterior Wall	10	ABOVE AVG.	100
Roof Structur	03	GABLE/HIP	100
Roof Cover	12	MODULAR MT	100
Interior Wall	04	PLYWOOD	100
Interior Floor	14	CARPET	90
Interior Floor	08	SHT VINYL	10
Air Condition	03	CENTRAL	100
Heating Type	02	CONVECTION	100
Bedrooms		2	100
Bathrooms		1	100
Frame	01	NONE	100
Stories	1.	1.	100
Architectual Units	05	CONV	100
Condition Adj	03	03	100
Kitchen Adjus	01	01	100
Quality	05	05	
DOR CODE	0100	SINGLE FAMILY	
MAP NUM		MKT AREA	02
NEIGHBORHOOD/LOC	19716.010	1.00/	
AREA TYPE	TOTAL GROSS AREA	PCT OF BASE	YEAR
BAS	878	100	
FCP	768	25	
UOP	562	20	
TOTALS	2,208		1,182

MARKET ADJUSTMENTS												
TYPE	MDL	EFF. AREA	TOT ADJ PTS	EFF. BASE RATE	REPL. COST NEW	AYB	EYB	ECON	FNCT	NORM	% COND	
1	SFR	PILING	0%	- 2023								
				Heated Area: 878				HX Base Yr				

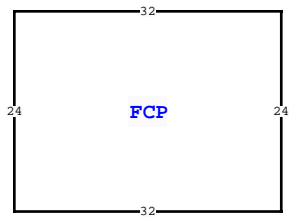

COLUMBIA COUNTY PROPERTY			
VALUATION SUMMARY			PAGE 1 of 1
VALUATION BY		STANDARD	
Tax Group: 3	Tax Dist:		
BUILDING MARKET VALUE	99,550		
TOTAL MARKET OB/XF VALUE	2,424		
TOTAL LAND VALUE - MARKET	56,250		
TOTAL MARKET VALUE	158,224		
SOH/AGL Deduction	0		
ASSESSED VALUE	158,224		
TOTAL EXEMPTION VALUE	0		
BASE TAXABLE VALUE	158,224		
TOTAL JUST VALUE	158,224		
NCON VALUE	0		
INCOME VALUE	0		
PREVIOUS YEAR MKT VALUE	158,224		
LAND:1:1: 0.30 AC			
SALE:2:3: MONEY BORROWED FOR FUTURE IMPROVEMENTS			
SALE:2:2: RELATED, AND SELLING PRICE REFLECTED EXT			
SALE:2:1: SALE CHECKED BY JERRY, BUYER & SELLER AR			
PERMIT NUM	DESCRIPTION	AMT	ISSUED
SALES DATA			
OFF RECORD Number	DATE	TYPE INST	Q / V / RSN CD
1469/1197	6/21/2022	WD Q	I 01
GRANTOR: WILSON ROBERT E			
GRANTEE: UNDER ALL LLC			
1005/2161	1/26/2004	QC Q	I 01
GRANTOR: TIDEWATER SERVICES			
GRANTEE: ROBERT E WILSON			
BUILDING NOTES			
BUILDING DIMENSIONS			
BAS= W21 S24 E32 N5 UOP= E10S5 E8 N34 W29 S10 E21 S11 W10 S8\$ N8 E10 N11 W21 \$ PTR=N30 FCP= N24 W32 S24 E32\$ S30\$.			

EXTRA FEATURES		200 SW MERIDIAN CT, FORT WHITE	
L N	OB/XF CODE	DESCRIPTION	ADJ R
1	0190	FPLC PF	1,200.00
2	0166	CONC, PAVMT	0.00

L N	OB/XF CODE	DESCRIPTION	BLD CAP	L	W	UNITS	UT	Adj R	ADJ UNIT PRICE	ORIG COND	YEAR ON	YEAR ACTUAL	Q	% COND	OB/XF MKT VALUE	NOTES
1	0190	FPLC PF	0	0	0	1.00	UT	1,200.00	1,200.00	100	0	0	3	100	1,200	
2	0166	CONC, PAVMT	0	0	0	1.00	UT	0.00	0.00	100	0	0	3	100	1,224	

LAND DESCRIPTION		TOTAL OB/XF 2,424																						
L N	USE CODE	CLS	LAND USE DESCRIPTION	CAP	R D	LOC ZONE	FRONT	DEPTH	TOT LND UTS	UNIT TYPE	D T	DPH FACT	% COND	TOT ADJ	UNIT PRICE	ADJ UNIT PRICE	LAND VALUE	OTHER ADJUSTMENTS AND NOTES	YEAR	DENSITY	DECL	FRZ	YR	CONSRV
1	0100	C	SFR	0		A-1	0.00	0.00	75.00	FF		1.00	1.00	1.00	750.00	750.00	56,250							