

COMM SE COR, RUN W 2641.60 FT, N
166.33 FT, N 1356.70 FT FOR POB,
550.20 FT, W 833.75 FT, S 550.15

PAYOR PETER
710 SW BUSSEY GLEN
FORT WHITE, FL 32038

2026

18-7S-17-10021-013

ELEMENT		BUILDING CHARACTERISTICS			
CD	CONSTRUCTION				
51	LOG 100				
08	IRREGULAR 100				
14	PREFIN MT 100				
05	DRYWALL 100				
14	CARPET 70				
12	HARDWOOD 30				
03	CENTRAL 100				
04	AIR DUCTED 100				
	3 100				
	2.5 100				
02	WOOD FRAME 100				
1.5	1.5 100				
05	CONV 100				
	0 100				
03	03 100				
01	01 100				
06	06				
5000	IMPROVED AG				
	MKT AREA		02		
NEIGHBORHOOD/LOC		18717.00	1.00/		
AREA TYPE	TOTAL GROSS AREA	PCT OF BASE	YEAR	TOT ADJ AREA	SUBAREA MARKET VALUE
BAS	2,650	100		2,650	297,633
FGR	625	55		344	38,636
FOP	120	30		36	4,043
FSP	380	40		152	17,072
FUS	1,284	100		1,284	144,211
TOTALS	5,059			4,466	501,595

MARKET ADJUSTMENTS											
TYPE	MDL	EFF. AREA	TOT ADJ PTS	EFF. BASE RATE	REPL. COST NEW	AYB	EYB	ECON	FNCT	NORM	% COND
0100	01	4,466	126.9418	142.17	634,931	2004	2004	0	0	21.00	79.00
1 SINGLE FAM 100% - 2020 Heated Area: 3934 HX Base Yr 2020											

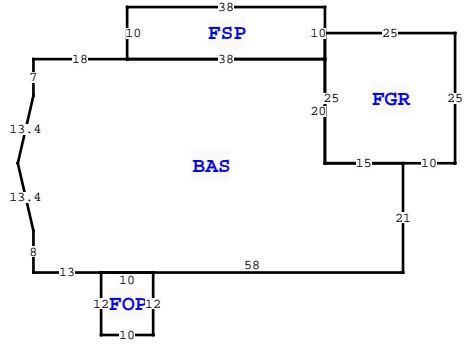
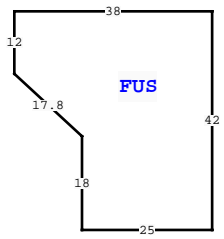

COLUMBIA COUNTY PROPERTY				PAGE 1 of 1	3	
VALUATION SUMMARY						
VALUATION BY				STANDARD		
Tax Group: 3				Tax Dist:		
BUILDING MARKET VALUE				501,595		
TOTAL MARKET OB/XF VALUE				20,470		
TOTAL LAND VALUE - MARKET				115,500		
TOTAL MARKET VALUE				537,293		
SOH/AGL Deduction				133,325		
ASSESSED VALUE				403,968		
TOTAL EXEMPTION VALUE				HX HB 51,411		
BASE TAXABLE VALUE				352,557		
TOTAL JUST VALUE				637,565		
NCON VALUE				0		
INCOME VALUE						
PREVIOUS YEAR MKT VALUE				623,204		
SALE:1:1: CREATING A TRUST ACCOUNT #2001						
PERMIT NUM	DESCRIPTION	AMT	ISSUED			
000051387	Generator	0	11/04/2024			
22863	POOL	200	03/02/2005			
20577	SFR	668	04/02/2003			
SALES DATA						
OFF RECORD Number	DATE	TYPE INST	Q / U	V / I	RSN CD	SALE PRICE
1531/503	1/09/2025	LE	U	I	14	0
GRANTOR: PAYOR PETER (ENH LE)						
GRANTEE: PAYOR PETER REVOCAB						
1355/1115	3/12/2018	WD	Q	I	01	425,000
GRANTOR: BONNITA M FLYNN						
GRANTEE: PETER PAYOR						
BUILDING NOTES						
BUILDING DIMENSIONS						
BAS= W18 S7 L3 D13 D13 R3 S8 E13 FOP= S12 E10 N12 W10\$ E58 N21 FGR= E10 N25 W25 S25 E15\$ W15 N20 FSP= N10 W38 S10 E38\$ W38\$ PTR= N30 FUS= N42 W38 S12 R13 D12 S18 E25\$ S30\$.						

EXTRA FEATURES																
L N	OB/XF CODE	DESCRIPTION	BLD CAP	L	W	UNITS	UT	Adj R	ADJ UNIT PRICE	ORIG COND	YEAR ON	YEAR ACTUAL	Q	% COND	OB/XF MKT VALUE	NOTES
1	0190	FPLC PF	0	100	0	1.00	UT	1,200.00	1,200.00	100	2004	2004	3	100	1,200	
2	0166	CONC, PAVMT	0	100	0	2,442.00	UT	2.00	2.00	100	2004	2004	3	100	4,884	
3	0280	POOL R/CON	0	100	12	264.00	UT	70.00	70.00	100	2005	2005	3	47	8,686	
4	0104	GENERATOR	0	100	0	1.00	UT	6,000.00	6,000.00	100	2026	2025		95	5,700	

LAND DESCRIPTION															TOTAL OB/XF									
L N	USE CODE	CLS	LAND USE DESCRIPTION	CAP	R D	LOC ZONE	FRONT	DEPTH	TOT LND UTS	UNIT TYPE	D T	DPH FACT	% COND	TOT ADJ	UNIT PRICE	ADJ UNIT PRICE	LAND VALUE	OTHER ADJUSTMENTS AND NOTES	YEAR	DENSITY	DECL	FRZ	YR	CONSRV
1	5500	A	TIMBER 2	0		A-1	0.00	0.00	9.50	AC		1.00	1.00	1.00	445.00	445.00	4,228							
2	9910	M	MKT. VAL. AG	0		A-1	0.00	0.00	9.50	AC		1.00	1.00	1.00	11,000.00	11,000.00	104,500							
3	0100	C	SFR	100			0.00	0.00	1.00	AC		1.00	1.00	1.00	11,000.00	11,000.00	11,000							