

AKA LOT 12 SUMMER'S ACRES S/D UN
COR, RUN S 80.15 FT TO S R/W CR-
R/W 698.08 FT, S 652.02 FT FOR P

PEDEN NICHOLAS D/PEDEN MELODY K
296 SW STERLING TER
HIGH SPRINGS, FL 32643

2026

16-7S-17-10006-112



BUILDING CHARACTERISTICS		CONSTRUCTION	
ELEMENT	CD		
Exterior Wall	32	HARDIE BRD	100
Roof Structur	08	IRREGULAR	100
Roof Cover	03	COMP SHNGL	100
Interior Wall	05	DRYWALL	100
Interior Floor	12	HARDWOOD	80
Interior Floor	15	HARDTILE	20
Air Condition	03	CENTRAL	100
Heating Type	04	AIR DUCTED	100
Bedrooms		3	100
Bathrooms		2.5	100
Frame	02	WOOD FRAME	100
Stories	1.	1.	100
Architectual	05	CONV	100
Units		0	100
Quality	07	07	
DOR CODE	0100	SINGLE FAMILY	
MAP NUM		MKT AREA	02
NEIGHBORHOOD/LOC	16717.010	1.00/	
AREA TYPE	TOTAL GROSS AREA	PCT OF BASE	YEAR
BAS	2,333	100	
FGR	672	55	
FOP	281	30	
FOP	432	30	
FUS	441	100	
TOTALS	4,159		

MARKET ADJUSTMENTS											
TYPE	MDL	EFF. AREA	TOT ADJ PTS	EFF. BASE RATE	REPL. COST NEW	AYB	EYB	ECON	FNCT	NORM	% COND
0100	01	3,358	123.7720	138.62	465,486	2009	2009	0	0	16.00	84.00
1 SINGLE FAM 100% - 2010 Heated Area: 2774 HX Base Yr 2010											

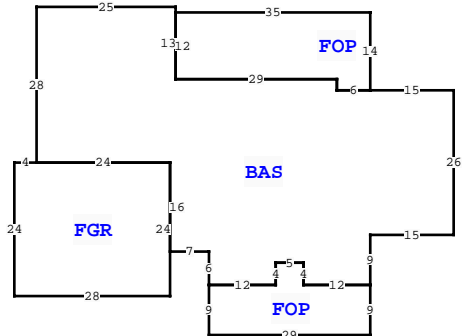
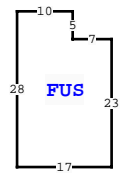

COLUMBIA COUNTY PROPERTY		PAGE 1 of 1	3
VALUATION SUMMARY			
VALUATION BY		STANDARD	
Tax Group: 3		Tax Dist:	
BUILDING MARKET VALUE		391,008	
TOTAL MARKET OB/XF VALUE		2,000	
TOTAL LAND VALUE - MARKET		114,950	
TOTAL MARKET VALUE		507,958	
SOH/AGL Deduction		267,777	
ASSESSED VALUE		240,181	
TOTAL EXEMPTION VALUE		51,411	
BASE TAXABLE VALUE		188,770	
TOTAL JUST VALUE		507,958	
NCON VALUE		0	
INCOME VALUE			
PREVIOUS YEAR MKT VALUE		496,938	

PERMIT NUM	DESCRIPTION	AMT	ISSUED
27895	SFR	1,136	06/19/2009

SALES DATA						
OFF RECORD Number	DATE	TYPE INST	Q / U	V / I	RSN CD	SALE PRICE
1545/99	7/18/2025	LE	U	I	14	0
GRANTOR: PEDED NICHOLAS D (LIF)						
GRANTEE: PEDED FAMILY TRUST						
0979/0442	3/26/2003	WD	Q	V		42,000
GRANTOR: SANDRA SUMMERS-VARNER						
GRANTEE: NICHOLAS D & MELODY						

EXTRA FEATURES																
L N	OB/XF CODE	DESCRIPTION	BLD CAP	L	W	UNITS	UT	Adj R	ADJ UNIT PRICE	ORIG COND	YEAR ON	YEAR ACTUAL	Q	% COND	OB/XF MKT VALUE	NOTES
1	0180	FPLC 1STRY	0	100	0	1.00	UT	2,000.00	2,000.00	100	2009	2009	3	100	2,000	

296 SW STERLING TER, HIGH SPRINGS

BLD DATE		LGL DATE	05/06/2026	MLU
XF DATE		LAND DATE		
INC DATE		AG DATE		

BUILDING NOTES									

BUILDING DIMENSIONS
 BAS= W25 S28 FGR= W4 S24 E28 N24 W24\$ E24 S16 E7 S6 FOP= S9
 E29 N9 W12 N4 W5 S4 W12\$ E12 N4 E5 S4 E12 N9 E15 N26 W15 FOP=
 N14 W35 S12 E29 S2 E6\$ W6 N2 W29 N13\$ PTR= N30 FUS= N23 W7 N5
 W10 S28 E17\$ S30\$.

LAND DESCRIPTION										TOTAL OB/XF														
L N	USE CODE	CLS	LAND USE DESCRIPTION	CAP	R D	LOC ZONE	FRONT	DEPTH	TOT LND UTS	UNIT TYPE	D T	DPH FACT	% COND	TOT ADJ	UNIT PRICE	ADJ UNIT PRICE	LAND VALUE	OTHER ADJUSTMENTS AND NOTES	YEAR	DENSITY	DECL	FRZ	YR	CONSRV
1	0100	C	SFR	100		A-1	0.00	0.00	10.45	AC		1.00	1.00	1.00	11,000.00	11,000.00	114,950							