

COMM SW COR OF NW1/4 OF NW1/4, N
2449.44 FT, S 3 DEG E 762.05 FT
1351.15 FT TO W R/W OF MARY RD,

STILLINGS GERALD D SR/BING PAMELA M
432 SW MARY TER
LAKE CITY, FL 32024

2026

14-5S-15-00459-215



ELEMENT		BUILDING CHARACTERISTICS			
CD	CONSTRUCTION				
08	WD OR PLY 100				
03	GABLE/HIP 100				
03	COMP SHNGL 100				
05	DRYWALL 100				
02	MIN PLYWD 80				
09	PINE WOOD 20				
01	NONE 100				
02	CONVECTION 100				
	2 100				
	1.5 100				
01	NONE 100				
1.	1. 100				
05	CONV 100				
	0 100				
03	03 100				
01	01 100				
05	05				
5000	IMPROVED AG				
	MKT AREA		02		
14515.030	1.00/				
AREA TYPE	TOTAL GROSS AREA	PCT OF BASE	YEAR	TOT ADJ AREA	SUBAREA MARKET VALUE
BAS	288	100		288	19,076
FGR	480	55		264	17,486
FUS	528	100		528	34,972
UOP	120	20		24	1,590
UOP	120	20		24	1,590
UOP	120	20		24	1,590
TOTALS	1,656			1,152	76,303

MARKET ADJUSTMENTS											
TYPE	MDL	EFF. AREA	TOT ADJ PTS	EFF. BASE RATE	REPL. COST NEW	AYB	EYB	ECON	FNCT	NORM	% COND
0100	01	1,152	90.9840	101.90	117,389	1996	1996	0	0	35.00	65.00
1 SINGLE FAM 100% - 1995 Heated Area: 816 HX Base Yr 1995											

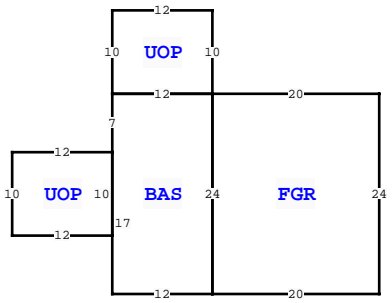
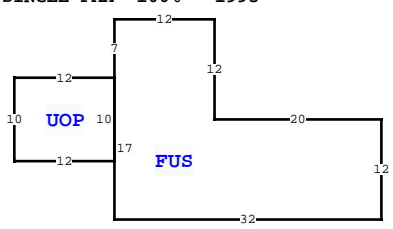

COLUMBIA COUNTY PROPERTY		PAGE 1 of 1	3
VALUATION SUMMARY			
VALUATION BY			STANDARD
Tax Group: 3	Tax Dist:		
BUILDING MARKET VALUE			76,303
TOTAL MARKET OB/XF VALUE			8,500
TOTAL LAND VALUE - MARKET			246,755
TOTAL MARKET VALUE			101,767
SOH/AGL Deduction			58,688
ASSESSED VALUE			43,079
TOTAL EXEMPTION VALUE	HX HB		25,000
BASE TAXABLE VALUE			18,079
TOTAL JUST VALUE			331,558
NCON VALUE			0
INCOME VALUE			
PREVIOUS YEAR MKT VALUE			302,528

PERMIT NUM	DESCRIPTION	AMT	ISSUED
10834	SFR	65	03/01/1996

SALES DATA						
OFF RECORD Number	DATE	TYPE INST	Q U	V I	RSN CD	SALE PRICE
1504/866	11/28/2023	LE U	I	14		100
GRANTOR: STILLINGS GERALD D SR						
GRANTEE: STILLINGS GERALD D						
1485/102	2/09/2023	LE U	I	14		0
GRANTOR: STILLINGS GERALD D SR						
GRANTEE: STILLINGS GERALD D						

EXTRA FEATURES		432 SW MARY TER, LAKE CITY														
L N	OB/XF CODE	DESCRIPTION	BLD CAP	L	W	UNITS	UT	Adj R	ADJ UNIT PRICE	ORIG COND	YEAR ON	YEAR ACTUAL	Q	% COND	OB/XF MKT VALUE	NOTES
1	0040	BARN, POLE	0	100	0	0			0.00	100	2016	2016	3	100	600	
2	0296	SHED METAL	0	100	0	0			0.00	100	2016	2016	3	100	900	
3	9945	Well/Sept	0	100	0	0			7,000.00	100			3	100	7,000	

BLD DATE		LGL DATE	
XF DATE		LAND DATE	
INC DATE		AG DATE	
		05/07/2026	MLU

BUILDING NOTES	

BUILDING DIMENSIONS	
FUS=[ORIG=0,-30] N12 W20 N12 W12 S7 S17 E32 \$	
FGR=[ORIG=0,0] S24 E20 N24 W20 \$	
BAS=[ORIG=0,0] W12 S7 S17 E12 N24 \$	
UOP=[ORIG=-12,7] W12 S10 E12 N10 \$	
UOP=[ORIG=0,0] N10 W12 S10 E12 \$	
UOP=[ORIG=-32,-47] W12 S10 E12 N10 \$	

LAND DESCRIPTION		TOTAL OB/XF 8,500																						
L N	USE CODE	CLS	LAND USE DESCRIPTION	CAP	R D	LOC ZONE	FRONT	DEPTH	TOT LND UTS	UNIT TYPE	D T	DPH FACT	% COND	TOT ADJ	UNIT PRICE	ADJ UNIT PRICE	LAND VALUE	OTHER ADJUSTMENTS AND NOTES	YEAR	DENSITY	DECL	FRZ	YR	CONSRV
1	0200	C	MBL HM	100		A-1	0.00	0.00	1.00	AC		1.00	1.00	1.00	8,500.00	8,500.00	8,500							
2	5500	A	TIMBER 2	0		00	0.00	0.00	19.02	AC		1.00	1.00	1.00	445.00	445.00	8,464							
3	9910	M	MKT.VAL.AG	0		00	0.00	0.00	19.02	AC		1.00	1.00	1.00	8,500.00	8,500.00	161,670							
4	9910	M	MKT.VAL.AG	0		00	0.00	0.00	9.01	AC		1.00	1.00	1.00	8,500.00	8,500.00	76,585							