

| BUILDING CHARACTERISTICS |                  | CONSTRUCTION  |      |
|--------------------------|------------------|---------------|------|
| ELEMENT                  | CD               |               |      |
| Exterior Wall            | 32               | HARDIE BRD    | 80   |
| Exterior Wall            | 21               | STONE         | 20   |
| Roof Structure           | 08               | IRREGULAR     | 100  |
| Roof Cover               | 12               | MODULAR MT    | 100  |
| Interior Wall            | 05               | DRYWALL       | 100  |
| Interior Floor           | 13               | LAM/VNLPLK    | 80   |
| Interior Floor           | 15               | HARDTILE      | 20   |
| Air Condition            | 03               | CENTRAL       | 100  |
| Heating Type             | 04               | AIR DUCTED    | 100  |
| Bedrooms                 |                  | 3             | 100  |
| Bathrooms                |                  | 2             | 100  |
| Frame                    | 01               | NONE          | 100  |
| Stories                  | 1.               | 1.            | 100  |
| Architectual             | 05               | CONV          | 100  |
| Units                    |                  | 0             | 100  |
| Condition Adj            | 03               | 03            | 100  |
| Kitchen Adjus            | 01               | 01            | 100  |
| Quality                  | 05               | 05            |      |
| DOR CODE                 | 0100             | SINGLE FAMILY |      |
| MAP NUM                  |                  | MKT AREA      | 06   |
| NEIGHBORHOOD/LOC         | 12416.010        | 1.00/         |      |
| AREA TYPE                | TOTAL GROSS AREA | PCT OF BASE   | YEAR |
| BAS                      | 1,664            | 100           |      |
| FGR                      | 480              | 55            |      |
| FOP                      | 16               | 30            |      |
| FSP                      | 240              | 40            |      |
| HGR                      | 1,280            | 45            |      |
| TOTALS                   | 3,680            |               |      |

| MARKET ADJUSTMENTS |            |           |             |                |                   |     |     |      |      |                 |        |  |  |
|--------------------|------------|-----------|-------------|----------------|-------------------|-----|-----|------|------|-----------------|--------|--|--|
| TYPE               | MDL        | EFF. AREA | TOT ADJ PTS | EFF. BASE RATE | REPL. COST NEW    | AYB | EYB | ECON | FNCT | NORM            | % COND |  |  |
| 1                  | SINGLE FAM | 100%      | - 2021      |                | Heated Area: 1664 |     |     |      |      | HX Base Yr 2021 |        |  |  |

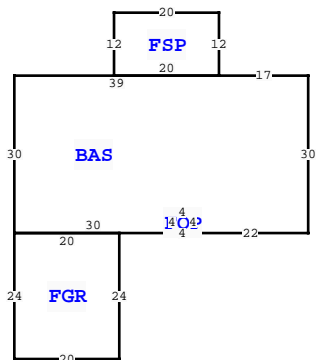
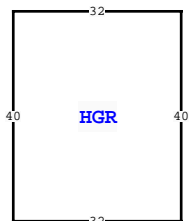

| COLUMBIA COUNTY PROPERTY  |           |  |             |
|---------------------------|-----------|--|-------------|
| VALUATION SUMMARY         |           |  | PAGE 1 of 1 |
| VALUATION BY              |           |  | STANDARD    |
| Tax Group: 2              | Tax Dist: |  |             |
| BUILDING MARKET VALUE     |           |  | 236,818     |
| TOTAL MARKET OB/XF VALUE  |           |  | 3,023       |
| TOTAL LAND VALUE - MARKET |           |  | 52,500      |
| TOTAL MARKET VALUE        |           |  | 292,341     |
| SOH/AGL Deduction         |           |  | 138,908     |
| ASSESSED VALUE            |           |  | 153,433     |
| TOTAL EXEMPTION VALUE     | HX HB     |  | 51,411      |
| BASE TAXABLE VALUE        |           |  | 102,022     |
| TOTAL JUST VALUE          |           |  | 292,341     |
| NCON VALUE                |           |  | 0           |
| INCOME VALUE              |           |  |             |
| PREVIOUS YEAR MKT VALUE   |           |  | 295,824     |

| PERMIT NUM | DESCRIPTION       | AMT    | ISSUED     |
|------------|-------------------|--------|------------|
| 000049697  | Solar Power Syste | 14,400 | 04/29/2024 |
| 000049217  | Solar Power Syste | 14,400 | 02/15/2024 |
| 6958       | GARAGE            | 10,000 | 03/22/1993 |
| 6646       | SFR               | 42,000 | 12/07/1992 |

| SALES DATA                    |           |           |       |       |        |            |
|-------------------------------|-----------|-----------|-------|-------|--------|------------|
| OFF RECORD Number             | DATE      | TYPE INST | Q / U | V / I | RSN CD | SALE PRICE |
| 1436/355                      | 4/27/2021 | WD        | Q     | V     | 04     | 21,000     |
| GRANTOR: CORBETT MICHAEL T    |           |           |       |       |        |            |
| GRANTEE: MAXWELL GLEN         |           |           |       |       |        |            |
| 1412/0314                     | 5/21/2020 | WD        | Q     | I     | 01     | 225,000    |
| GRANTOR: MICHAEL T & JUDITH L |           |           |       |       |        |            |
| GRANTEE: GLEN & NANCY MAXWEL  |           |           |       |       |        |            |

| EXTRA FEATURES |            |             |         |     |   |          |    |       |                |           |         |             |   |        |                 |       |
|----------------|------------|-------------|---------|-----|---|----------|----|-------|----------------|-----------|---------|-------------|---|--------|-----------------|-------|
| L N            | OB/XF CODE | DESCRIPTION | BLD CAP | L   | W | UNITS    | UT | Adj R | ADJ UNIT PRICE | ORIG COND | YEAR ON | YEAR ACTUAL | Q | % COND | OB/XF MKT VALUE | NOTES |
| 1              | 0166       | CONC, PAVMT | 0       | 100 | 0 | 1,209.00 | UT | 2.50  | 2.50           | 100       | 0       | 0           | 3 | 100    | 3,023           |       |

| BUILDING NOTES           |  |  |  |
|--------------------------|--|--|--|
| BLD DATE                 |  |  |  |
| LGL DATE                 |  |  |  |
| LAND DATE 04/03/2025 MLU |  |  |  |
| XF DATE                  |  |  |  |
| AG DATE                  |  |  |  |

| BUILDING DIMENSIONS   |  |  |  |
|---|--|--|--|
| BAS= W17 FSP= N12 W20 S12 E20\$ W39 S30 FGR= S24 E20 N24 W20\$ E30 FOP= E4 N4 W4 S4\$ N4 E4 S4 E22 N30\$ PTR= N30 HGR= N40 W32 S40 E32\$ S30\$. |  |  |  |

| LAND DESCRIPTION |          |     |                      |     |     |          |       |       |             |           |     |          |        | TOTAL OB/XF |            |                |            |                             |      |         |      |     |    |        |
|------------------|----------|-----|----------------------|-----|-----|----------|-------|-------|-------------|-----------|-----|----------|--------|-------------|------------|----------------|------------|-----------------------------|------|---------|------|-----|----|--------|
| L N              | USE CODE | CLS | LAND USE DESCRIPTION | CAP | R D | LOC ZONE | FRONT | DEPTH | TOT LND UTS | UNIT TYPE | D T | DPH FACT | % COND | TOT ADJ     | UNIT PRICE | ADJ UNIT PRICE | LAND VALUE | OTHER ADJUSTMENTS AND NOTES | YEAR | DENSITY | DECL | FRZ | YR | CONSRV |
| 1                | 0100     | C   | SFR                  | 100 |     | RSF-1    | 0.00  | 0.00  | 1.00        | LT        |     | 1.00     | 1.00   | 1.00        | 35,000.00  | 35,000.00      | 35,000     |                             |      |         |      |     |    |        |
| 2                | 0000     | C   | VAC RES              | 100 |     |          |       |       | 0.50        | LT        |     | 1.00     | 1.00   | 1.00        | 35,000.00  | 35,000.00      | 17,500     |                             |      |         |      |     |    |        |