

BUILDING CHARACTERISTICS		CONSTRUCTION	
ELEMENT	CD		
Exterior Wall	31	VINYL SID	100
Roof Structur	03	GABLE/HIP	100
Roof Cover	03	COMP SHNGL	100
Interior Wall	05	DRYWALL	100
Interior Floo	14	CARPET	90
Interior Floo	11	CLAY TILE	10
Air Condition	03	CENTRAL	100
Heating Type	04	AIR DUCTED	100
Bedrooms		3	100
Bathrooms		2.5	100
Frame	01	NONE	100
Stories	2.	2.	100
Architectual Units	05	CONV	100
Condition Adj	01	01	100
Kitchen Adjus	01	01	100
Quality	05	05	
DOR CODE	0100	SINGLE FAMILY	
MAP NUM		MKT AREA	01
NEIGHBORHOOD/LOC	9316.0100	1.00/	
AREA TYPE	TOTAL GROSS AREA	PCT OF BASE	YEAR
BAS	1,462	100	
FGR	572	55	
FOP	272	30	
FSP	153	40	
FSP	187	40	
FST	63	55	
FST	98	55	
FUS	728	100	
TOTALS	3,535		

MARKET ADJUSTMENTS												
TYPE	MDL	EFF. AREA	TOT ADJ PTS	EFF. BASE RATE	REPL. COST NEW	AYB	EYB	ECON	FNCT	AP	NORM	% COND
0100	01	2,812	87.2525	97.72	274,789	1996	1996	0	0	20	35.00	45.00
1 SINGLE FAM			100% - 2017	Heated Area: 2190			HX Base Yr 2017					

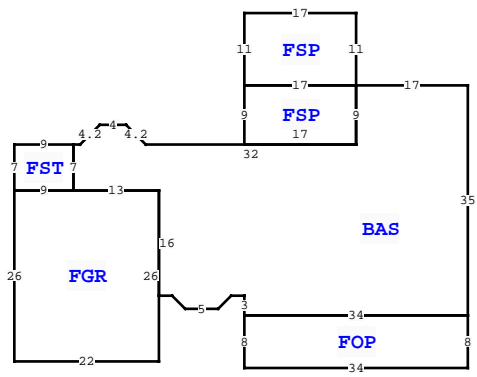
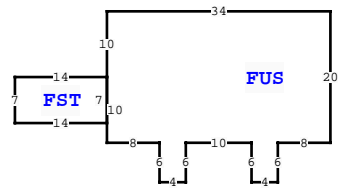

COLUMBIA COUNTY PROPERTY			
VALUATION SUMMARY			PAGE 1 of 1
VALUATION BY		STANDARD	
Tax Group: 3	Tax Dist:		
BUILDING MARKET VALUE			123,655
TOTAL MARKET OB/XF VALUE			4,660
TOTAL LAND VALUE - MARKET			44,000
TOTAL MARKET VALUE			172,315
SOH/AGL Deduction			47,726
ASSESSED VALUE			124,589
TOTAL EXEMPTION VALUE	HX HB	51,411	
BASE TAXABLE VALUE			73,178
TOTAL JUST VALUE			172,315
NCON VALUE			0
INCOME VALUE			
PREVIOUS YEAR MKT VALUE			168,315

PERMIT NUM	DESCRIPTION	AMT	ISSUED
000041967	Roof Replacement	17,600	05/20/2021

SALES DATA						
OFF RECORD Number	DATE	TYPE INST	Q / U	V / I	RSN CD	SALE PRICE
1319/0251	7/14/2016	WD	U	I	12	109,900
GRANTOR: US BANK TRUST, NA AS						
GRANTEE: DEBRA A ROBINSON						
1296/1161	5/27/2015	CT	U	I	18	100
GRANTOR: CLERK OF COURT (BARBE)						
GRANTEE: US BANK TRUST, NA A						

EXTRA FEATURES												
L N	OB/XF CODE	DESCRIPTION	BLD	CAP	L	W	UNITS	UT	Adj R	ADJ UNIT PRICE	ORIG COND	YEAR ON
1	0166	CONC, PAVMT	0	100	0	0	440.00	UT	1.50	1.50	100	1996
2	0190	FPLC PF	0	100	0	0	1.00	UT	1,200.00	1,200.00	100	1996
3	0166	CONC, PAVMT	0	100	0	0	1.00	UT	0.00	0.00	100	1996
4	0070	CARPORT UF	0	100	0	0	1.00	UT	1,200.00	1,200.00	100	2023

BUILDING NOTES			
BLD DATE			
XF DATE			
INC DATE			
LGL DATE	04/22/2026	MLU	
LAND DATE			
AG DATE			

BUILDING DIMENSIONS												
BAS= W17 FSP= N11 W17 S11 E17\$ FSP= W17 S9 E17 N9 \$ S9 W32												
U3 L3 W4 L3 D3 W1 FST= W9 S7 E9 N7\$ S7 FGR= W9S26 E22 N26												
W13 \$ E13 S16 E2 D2 R2 E5 R2 U2 E2 S3 FOP= S8 E34 N8 W34\$												
E34 N35\$ PTR= N30 FUS= N6 E8 N20 W34 S10 FST= W14 S7 E14 N7\$												
S10 E8 S6E4 N6 E10 S6 E4\$ S30\$.												

LAND DESCRIPTION													TOTAL OB/XF												
L N	USE CODE	CLS	LAND USE DESCRIPTION	CAP	R D	LOC ZONE	FRONT	DEPTH	TOT LND UTS	UNIT TYPE	D T	DPH FACT	% COND	TOT ADJ	UNIT PRICE	ADJ UNIT PRICE	LAND VALUE	OTHER ADJUSTMENTS AND NOTES	YEAR	DENSITY	DECL	FRZ	YR	CONSRV	
1	0100	C	SFR	100		A-1	0.00	0.00	1.00	LT		1.00	1.00	0.80	55,000.00	44,000.00	44,000								