

COMM NW COR OF LOT 1 BLOCK B HOL
 RUN S 58.41 FT, W 808.30 FT FOR
 DEG E 52.46 FT, N 80 DEG W 513.8

LANG JUSTIN/LANG LINDA
 573 SW HIDEWAY DR
 LAKE CITY, FL 32025

2026

07-4S-17-08110-004



BUILDING CHARACTERISTICS		CONSTRUCTION	
ELEMENT	CD		
Exterior Wall	31	VINYL SID	100
Roof Structur	08	IRREGULAR	100
Roof Cover	03	COMP SHNGL	100
Interior Wall	05	DRYWALL	100
Interior Floor	14	CARPET	70
Interior Floor	12	HARDWOOD	30
Air Condition	03	CENTRAL	100
Heating Type	04	AIR DUCTED	100
Bedrooms		3	100
Bathrooms		2.5	100
Frame	02	WOOD FRAME	100
Stories	1.5	1.5	100
Architectual	05	CONV	100
Units		0	100
Condition Adj	03	03	100
Kitchen Adjus	01	01	100
Quality	06	06	
DOR CODE	0100	SINGLE FAMILY	
MAP NUM		MKT AREA	06
NEIGHBORHOOD/LOC	7417.00	1.00/	
AREA TYPE	TOTAL GROSS AREA	PCT OF BASE	YEAR
BAS	1,516	100	
FGR	729	55	
FOP	120	30	
FOP	214	30	
FUS	616	100	
TOTALS	3,195		

MARKET ADJUSTMENTS											
TYPE	MDL	EFF. AREA	TOT ADJ PTS	EFF. BASE RATE	REPL. COST NEW	AYB	EYB	ECON	FNCT	NORM	% COND
0100	01	2,633	119.0656	133.35	351,111	2005	2005	0	0	25.00	75.00
1 SINGLE FAM 100% - 2017 Heated Area: 2132 HX Base Yr 2017											

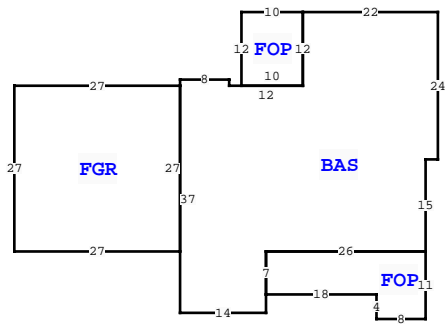
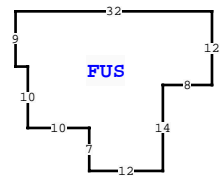

COLUMBIA COUNTY PROPERTY		PAGE 1 of 1	2
VALUATION SUMMARY			
VALUATION BY		STANDARD	
Tax Group: 2	Tax Dist:		
BUILDING MARKET VALUE		263,333	
TOTAL MARKET OB/XF VALUE		33,644	
TOTAL LAND VALUE - MARKET		13,824	
TOTAL MARKET VALUE		310,801	
SOH/AGL Deduction		84,519	
ASSESSED VALUE		226,282	
TOTAL EXEMPTION VALUE	HX HB	51,411	
BASE TAXABLE VALUE		174,871	
TOTAL JUST VALUE		310,801	
NCON VALUE		0	
INCOME VALUE			
PREVIOUS YEAR MKT VALUE		316,366	

PERMIT NUM	DESCRIPTION	AMT	ISSUED
22431	SFR	589	10/28/2004

SALES DATA						
OFF RECORD Number	DATE	TYPE INST	Q / U	V / I	RSN CD	SALE PRICE
1303/2765	11/06/2015	WD	Q	I	01	225,000
GRANTOR: RONALD MACK & CHERYLL						
GRANTEE: JUSTIN & LINDA LANG						
1228/0597	1/18/2012	WD	Q	I	01	170,000
GRANTOR: ROSEMARY E GOTTSCHALK						
GRANTEE: RONALD MACK & CHERY						

EXTRA FEATURES																	
L N	OB/XF CODE	DESCRIPTION	BLD	CAP	L	W	UNITS	UT	Adj R	ADJ UNIT PRICE	ORIG COND	YEAR ON	YEAR ACTUAL	Q	% COND	OB/XF MKT VALUE	NOTES
1	0120	CLFENCE 4	0	100	0	0	1.00	UT	0.00	0.00	100	2012	2012	3	100	500	
2	0180	FPLC 1STRY	0	100	0	0	1.00	UT	2,000.00	2,000.00	100	2005	2005	3	100	2,000	
3	0280	POOL R/CON	0	100	14	30	420.00	UT	70.00	70.00	100	2005	2005	3	47	13,818	
4	0282	POOL ENCL	0	100	0	0	1,184.00	UT	15.00	15.00	100	2005	2005	3	40	7,104	
5	0166	CONC, PAVMT	0	100	15	18	270.00	UT	2.00	2.00	30	2005	2005	3	30	162	
6	0296	SHED METAL	0	100	0	0	1.00	UT	0.00	0.00	100	2012	2012	3	100	1,400	
7	0251	LEAN TO W/	0	100	0	0	1.00	UT	0.00	0.00	100	2012	2012	3	100	600	
8	0031	BARN, MT AE	0	100	0	0	1.00	UT	0.00	0.00	100	2012	2012	3	100	4,000	
9	0166	CONC, PAVMT	0	100	0	0	2,030.00	UT	2.00	2.00	100	2012	2012	3	100	4,060	

BLD DATE		LGL DATE	
XF DATE		LAND DATE	
INC DATE		AG DATE	

BUILDING NOTES									
573 SW HIDEAWAY DR, LAKE CITY									

BUILDING DIMENSIONS									
BAS= W22 FOP= W10 S12 E10 N12\$ S12 W12 N1 W8 S1 FGR= W27 S27 E27 N27\$ S37 E14 N3 FOP= E18S4 E8 N11 W26 S7\$ N7 E26 N15 E2 N24\$ PTR= N30 FUS= N14 E8N12 W32 S9 E2 S10 E10 S7E12\$ S30\$.									

LAND DESCRIPTION															TOTAL OB/XF									
L N	USE CODE	CLS	LAND USE DESCRIPTION	CAP	R D	LOC ZONE	FRONT	DEPTH	TOT LND UTS	UNIT TYPE	D T	DPH FACT	% COND	TOT ADJ	UNIT PRICE	ADJ UNIT PRICE	LAND VALUE	OTHER ADJUSTMENTS AND NOTES	YEAR	DENSITY	DECL	FRZ	YR	CONSRV
1	0100	C	SFR	100			0.00	0.00	1.20	AC		1.00	1.00	0.72	16,000.00	11,520.00	13,824							