

BUILDING CHARACTERISTICS		CONSTRUCTION	
ELEMENT	CD		
Exterior Wall	32	HARDIE BRD	100
Roof Structur	08	IRREGULAR	100
Roof Cover	03	COMP SHNGL	100
Interior Wall	05	DRYWALL	100
Interior Floo	12	HARDWOOD	80
Interior Floo	15	HARDTILE	20
Air Condition	03	CENTRAL	100
Heating Type	04	AIR DUCTED	100
Bedrooms		3	100
Bathrooms		2	100
Frame	02	WOOD FRAME	100
Stories	1.	1.	100
Architectual	05	CONV	100
Units		0	100
Quality	07	07	
DOR CODE	0100	SINGLE FAMILY	
MAP NUM		MKT AREA	06
NEIGHBORHOOD/LOC	7417.0400	1.00/	
AREA TYPE	TOTAL GROSS AREA	PCT OF BASE	YEAR
BAS	1,974	100	
BAS	2,279	100	
FGR	504	55	
FOP	210	30	
FOP	212	30	
TOTALS	5,179		

MARKET ADJUSTMENTS											
TYPE	MDL	EFF. AREA	TOT ADJ PTS	EFF. BASE RATE	REPL. COST NEW	AYB	EYB	ECON	FNCT	NORM	% COND
1	SINGLE FAM	100%	2016		612,163	2015	2015	0	0	10.00	90.00
				Heated Area: 4253			HX Base Yr 2016				

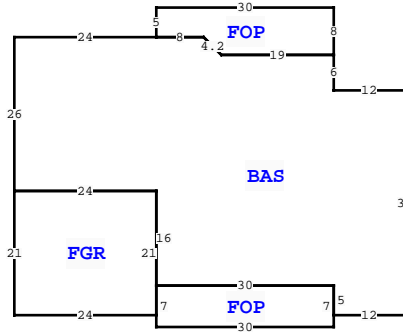
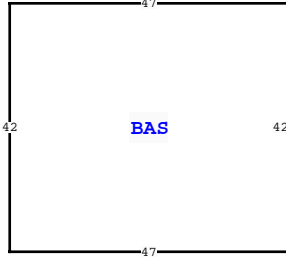

COLUMBIA COUNTY PROPERTY			
VALUATION SUMMARY			PAGE 1 of 1
VALUATION BY		STANDARD	
Tax Group: 2		Tax Dist:	
BUILDING MARKET VALUE		550,947	
TOTAL MARKET OB/XF VALUE		5,212	
TOTAL LAND VALUE - MARKET		35,000	
TOTAL MARKET VALUE		591,159	
SOH/AGL Deduction		201,763	
ASSESSED VALUE		389,396	
TOTAL EXEMPTION VALUE		101,411	
BASE TAXABLE VALUE		287,985	
TOTAL JUST VALUE		591,159	
NCON VALUE		0	
INCOME VALUE			
PREVIOUS YEAR MKT VALUE		597,280	
LAND:1:1: 0.50 AC.			
PERMIT NUM	DESCRIPTION	AMT	ISSUED
32456	SFR	927	11/06/2014
29124	PLANE HNGR	600	01/11/2011

SALES DATA						
OFF RECORD Number	DATE	TYPE INST	Q U	V I	RSN CD	SALE PRICE
1173/0841	5/15/2009	WD Q	Q	V	01	60,000
GRANTOR: WILLIAM T & JILL YOUN						
GRANTEE: THE HOUSTON TRUST						
1038/0932	2/16/2005	WD Q	Q	V		54,000
GRANTOR: F C CARROLL PROPERTIE						
GRANTEE: WILLIAM T & JILL YO						

EXTRA FEATURES															
L N	OB/XF CODE	DESCRIPTION	BLD CAP	L W	UNITS	UT	Adj R	ADJ UNIT PRICE	ORIG COND	YEAR ON	YEAR ACTUAL	Q	% COND	OB/XF MKT VALUE	NOTES
1	0166	CONC, PAVMT	0	100	24	32		768.00	100	2011	2011	3	100	1,536	
2	0166	CONC, PAVMT	0	100	0	0		1,838.00	100	2015	2015	3	100	3,676	

BLD DATE		LGL DATE	
XF DATE	INC DATE	LAND DATE	AG DATE
		04/14/2026	MLU

BUILDING NOTES	
BUILDING DIMENSIONS	
BAS= W12 N6 FOP= N8 W30 S5 E8 D3 R3 E19\$ W19 L3 U3 W8 W24 S26 FGR= S21 E24 N21 W24\$ E24 S16 FOP= S7 E30 N7 W30\$ E30 S5 E12 N38\$ PTR= N70 BAS= W47 S42 E47 N42\$ S70\$.	

LAND DESCRIPTION												TOTAL OB/XF												
L N	USE CODE	CLS	LAND USE DESCRIPTION	CAP	R D	LOC ZONE	FRONT	DEPTH	TOT LND UTS	UNIT TYPE	D T	DPH FACT	% COND	TOT ADJ	UNIT PRICE	ADJ UNIT PRICE	LAND VALUE	OTHER ADJUSTMENTS AND NOTES	YEAR	DENSITY	DECL	FRZ	YR	CONSRV
1	0100	C	SFR	100		RSF	113.00	191.00	1.00	LT		1.00	1.00	1.00	35,000.00	35,000.00	35,000							