

| BUILDING CHARACTERISTICS |    | CONSTRUCTION |     |
|--------------------------|----|--------------|-----|
| ELEMENT                  | CD |              |     |
| Exterior Wall            | 31 | VINYL SID    | 100 |
| Roof Structur            | 08 | IRREGULAR    | 100 |
| Roof Cover               | 03 | COMP SHNGL   | 100 |
| Interior Wall            | 05 | DRYWALL      | 100 |
| Interior Floo            | 13 | LAM/VNLPK    | 100 |
| Air Condition            | 03 | CENTRAL      | 100 |
| Heating Type             | 04 | AIR DUCTED   | 100 |
| Bedrooms                 |    | 3            | 100 |
| Bathrooms                |    | 3            | 100 |
| Frame                    |    | N/A          | 100 |
| Stories                  | 2. | 2.           | 100 |
| Architectual             | 05 | CONV         | 100 |
| Units                    |    | 0            | 100 |
| Condition Adj            | 04 | 04           | 100 |
| Kitchen Adjus            | 01 | 01           | 100 |

| MARKET ADJUSTMENTS |     |           |             |                |                |      |      |      |      |       |        |
|--------------------|-----|-----------|-------------|----------------|----------------|------|------|------|------|-------|--------|
| TYPE               | MDL | EFF. AREA | TOT ADJ PTS | EFF. BASE RATE | REPL. COST NEW | AYB  | EYB  | ECON | FNCT | NORM  | % COND |
| 0100               | 01  | 1,907     | 129.2098    | 144.72         | 275,981        | 2000 | 2000 | 0    | 0    | 31.25 | 68.75  |

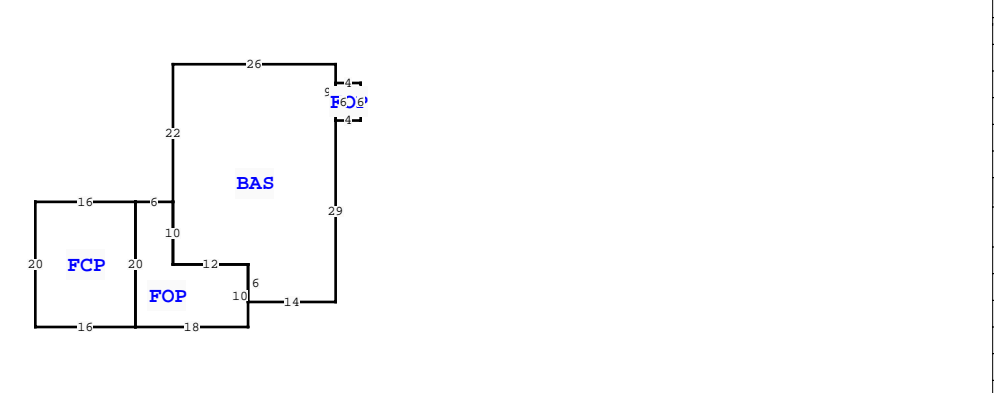

| COLUMBIA COUNTY PROPERTY  |           | PAGE 1 of 1 |
|---------------------------|-----------|-------------|
| VALUATION SUMMARY         |           |             |
| VALUATION BY              |           | STANDARD    |
| Tax Group: 1              | Tax Dist: |             |
| BUILDING MARKET VALUE     |           | 189,737     |
| TOTAL MARKET OB/XF VALUE  |           | 3,531       |
| TOTAL LAND VALUE - MARKET |           | 16,078      |
| TOTAL MARKET VALUE        |           | 209,346     |
| SOH/AGL Deduction         |           | 0           |
| ASSESSED VALUE            |           | 209,346     |
| TOTAL EXEMPTION VALUE     |           | 0           |
| BASE TAXABLE VALUE        |           | 209,346     |
| TOTAL JUST VALUE          |           | 209,346     |
| NCON VALUE                |           | 0           |
| INCOME VALUE              |           |             |
| PREVIOUS YEAR MKT VALUE   |           | 206,901     |

| PERMIT NUM | DESCRIPTION      | AMT    | ISSUED     |
|------------|------------------|--------|------------|
| 000044296  | Roof Replacement | 10,000 | 04/27/2022 |
| 1726       | SFR              | 363    | 01/18/2000 |

| SALES DATA        |           |           |       |       |        |            |
|-------------------|-----------|-----------|-------|-------|--------|------------|
| OFF RECORD Number | DATE      | TYPE INST | Q / U | V / I | RSN CD | SALE PRICE |
| 1459/1950         | 2/11/2022 | WD Q      | Q     | I     | 01     | 220,500    |

GRANTOR: SCHWARTZ STEVEN M  
GRANTEE: DAVIES CHRISTOPHER

| OFF RECORD Number | DATE       | TYPE INST | Q / U | V / I | RSN CD | SALE PRICE |
|-------------------|------------|-----------|-------|-------|--------|------------|
| 1398/1434         | 11/07/2019 | WD Q      | Q     | I     | 01     | 160,000    |

GRANTOR: BLUE SKY PROPERTY INV  
GRANTEE: SEVEN M & MARIE LEE

| QUALITY | CD |  |
|---------|----|--|
| 05      | 05 |  |

| DOR CODE |               |
|----------|---------------|
| 0100     | SINGLE FAMILY |

| MAP NUM | MKT AREA |    |
|---------|----------|----|
|         |          | 06 |

| EXTRA FEATURES |            |             |         |   |   |        |    |          |                |           |         |             |   |        |                 |       |
|----------------|------------|-------------|---------|---|---|--------|----|----------|----------------|-----------|---------|-------------|---|--------|-----------------|-------|
| L N            | OB/XF CODE | DESCRIPTION | BLD CAP | L | W | UNITS  | UT | Adj R    | ADJ UNIT PRICE | ORIG COND | YEAR ON | YEAR ACTUAL | Q | % COND | OB/XF MKT VALUE | NOTES |
| 1              | 0180       | FPLC 1STRY  | 0       | 0 | 0 | 1.00   | UT | 2,000.00 | 2,000.00       | 100       | 2000    | 2000        | 3 | 100    | 2,000           |       |
| 2              | 0166       | CONC, PAVMT | 0       | 0 | 0 | 754.00 | UT | 1.50     | 1.50           | 100       | 2000    | 2000        | 3 | 100    | 1,131           |       |
| 3              | 0296       | SHED METAL  | 0       | 0 | 8 | 80.00  | UT | 5.00     | 5.00           | 100       | 2000    | 2000        | 3 | 100    | 400             |       |

| TOTAL OB/XF                |  |  |  |  |  |  |  |  |  |  |  | 3,531 |  |  |  |  |
|----------------------------|--|--|--|--|--|--|--|--|--|--|--|-------|--|--|--|--|
| 1431 SE VALE CT, LAKE CITY |  |  |  |  |  |  |  |  |  |  |  |       |  |  |  |  |

| BUILDING NOTES |  |  |  |  |  |  |  |  |  |  |  |
|----------------|--|--|--|--|--|--|--|--|--|--|--|
|                |  |  |  |  |  |  |  |  |  |  |  |

| BUILDING DIMENSIONS   |  |  |  |  |  |  |  |  |  |  |  |
|---|--|--|--|--|--|--|--|--|--|--|--|
| BAS= W26 S22 FOP= W6 FCP= W16 S20 E16 N20\$ S20 E18 N10 W12 N10\$ S10 E12 S6 E14 N29 FOP= E4 N6 W4 S6\$ N9\$ PTR= N30 FUS= N32 W26 S32 E26\$ S30\$. |  |  |  |  |  |  |  |  |  |  |  |

| LAND DESCRIPTION |          |     |                      |     |     |          |        |        |             |           |     | TOTAL OB/XF |        |         |            |                |            |                             |      |         |      |     |    |        |
|------------------|----------|-----|----------------------|-----|-----|----------|--------|--------|-------------|-----------|-----|-------------|--------|---------|------------|----------------|------------|-----------------------------|------|---------|------|-----|----|--------|
| L N              | USE CODE | CLS | LAND USE DESCRIPTION | CAP | R D | LOC ZONE | FRONT  | DEPTH  | TOT LND UTS | UNIT TYPE | D T | DPH FACT    | % COND | TOT ADJ | UNIT PRICE | ADJ UNIT PRICE | LAND VALUE | OTHER ADJUSTMENTS AND NOTES | YEAR | DENSITY | DECL | FRZ | YR | CONSRV |
| 1                | 0100     | C   | SFR                  | 0   |     | *RSF-    | 250.00 | 129.00 | 10,719.00   | SF        |     | 1.00        | 1.00   | 1.00    | 1.50       | 1.50           | 16,078     |                             |      |         |      |     |    |        |