

BUILDING CHARACTERISTICS		
ELEMENT	CD	CONSTRUCTION
Exterior Wall	19	COMMON BRK 100
Roof Structur	03	GABLE/HIP 100
Roof Cover	03	COMP SHNGL 100
Interior Wall	05	DRYWALL 100
Interior Floo	14	CARPET 70
Interior Floo	08	SHT VINYL 30
Ceiling	02	F.NOT SUS 100
Air Condition	06	ENG CENTRL 100
Heating Type	09	ENG F AIR 100
Fixtures		151 100
Frame	02	WOOD FRAME 100
Story Height		10 100
RMS		43 100
Stories	1.	1. 100
Units		0 100
Condition Adj	03	03 100

MARKET ADJUSTMENTS														
TYPE	MDL	EFF. AREA	TOT ADJ PTS	EFF. BASE RATE	REPL. COST NEW	AYB	EYB	ECON	FNCT	NORM	% COND			
0710	04	24,927	112.4952	95.62	2,383,520	2000	2005	0	0	0	20.00	80.00		
1 EXCEP/ACLF 0% - 0 Heated Area: 23637 HX Base Yr														

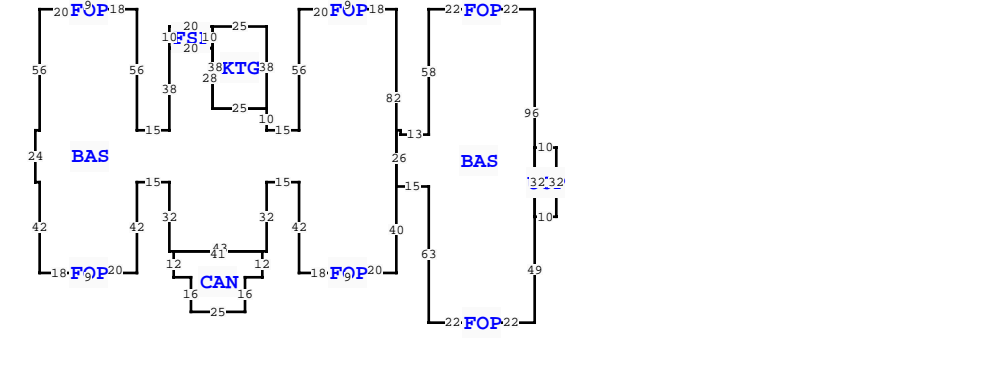

Quality	07	07			
DOR CODE	7400 HOMES FOR THE AGED				
MAP NUM		06			
NEIGHBORHOOD/LOC	5417.00	1.00/			
AREA TYPE	TOTAL GROSS AREA	PCT OF BASE	YEAR	TOT ADJ AREA	SUBAREA MARKET VALUE
BAS	7,449	100		7,449	569,818
BAS	15,238	100		15,238	1,165,646
CAN	892	30		268	20,501
FOP	20	30		6	459
FOP	20	30		6	459
FOP	28	30		8	612
FOP	28	30		8	612
FOP	28	30		8	612
FOP	28	30		8	612
FSP	200	40		80	6,120
TOTALS	26,691			24,927	1,906,816

** This building has 13 Sub-Areas
 1580 S MARION AVE, LAKE CITY

BLD DATE		LGL DATE	
XF DATE		LAND DATE	05/12/2026
INC DATE		AG DATE	MLU

EXTRA FEATURES																
L N	OB/XF CODE	DESCRIPTION	BLD CAP	L	W	UNITS	UT	Adj R	ADJ UNIT PRICE	ORIG COND	YEAR ON	YEAR ACTUAL	Q	% COND	OB/XF MKT VALUE	NOTES
1	0260	PAVEMENT-A	0	0	0	17,082.00	UT	0.90	0.90	100	2000	2000	3	100	15,374	
2	0166	CONC, PAVMT	0	0	6	90	UT	1.50	1.50	100	2000	2000	3	100	810	
3	0166	CONC, PAVMT	0	0	0	0	UT	2.00	2.00	100	2004	2004	3	100	1,800	
4	0260	PAVEMENT-A	0	0	0	0	UT	1.85	1.85	100	2007	2007	3	100	11,514	
5	0166	CONC, PAVMT	0	0	0	0	UT	3.00	3.00	100	2007	2007	3	100	960	

TOTAL OB/XF 30,458

LAND DESCRIPTION																								
L N	USE CODE	CLS	LAND USE DESCRIPTION	CAP	R D	LOC ZONE	FRONT	DEPTH	TOT LND UTS	UNIT TYPE	D T	DPHT FACT	% COND	TOT ADJ	UNIT PRICE	ADJ UNIT PRICE	LAND VALUE	OTHER ADJUSTMENTS AND NOTES	YEAR	DENSITY	DECL	FRZ	YR	CONSRV
1	7310	C	NURS HOME	0		RMF-2	0.00	0.00	122,839.00	SF		1.00	1.00	1.00	2.50	2.50	307,098							
2	1000	C	VACANT COMME	0			0.00	0.00	59,241.00	SF		1.00	1.00	1.00	2.50	2.50	148,102							
3	1000	C	VACANT COMME	0		00	0.00	0.00	22,694.00	SF		1.00	1.00	1.00	2.50	2.50	56,735							

COLUMBIA COUNTY PROPERTY				PAGE 1 of 2	1
VALUATION SUMMARY					
VALUATION BY		STANDARD			
Tax Group: 1		Tax Dist:			
BUILDING MARKET VALUE				2,937,650	
TOTAL MARKET OB/XF VALUE				30,458	
TOTAL LAND VALUE - MARKET				511,935	
TOTAL MARKET VALUE				3,480,043	
SOH/AGL Deduction				0	
ASSESSED VALUE				3,480,043	
TOTAL EXEMPTION VALUE				0	
BASE TAXABLE VALUE				3,480,043	
TOTAL JUST VALUE				3,480,043	
NCON VALUE				0	
INCOME VALUE				0	
PREVIOUS YEAR MKT VALUE				3,465,256	
LAND:3:1: .55 AC					
LAND:1:2: ORB 893-635. (2.82 AC)					
SALE:1:1: SALE IS FOR 10 AC VACANT LAND					

PERMIT NUM	DESCRIPTION	AMT	ISSUED
89	ADDN COMM	205	06/07/2007
89	ADDN COMM	3,111	03/14/2007
2902	ADDN COMM	1,955	03/23/2004
1705	COMMERCIAL	1,785	12/20/1999
611	COMMERCIAL	1,716	01/12/1996

SALES DATA						
OFF RECORD Number	DATE	TYPE INST	Q U	V I	RSN CD	SALE PRICE
1381/1392	3/01/2019	WD	U	I	30	6,295,900
GRANTOR: ETS WILLOWBROOK AT MA						
GRANTEE: ETS WILLOWBROOK PRO						
1381/1060	3/01/2019	WD	U	I	11	100
GRANTOR: ETS WILLOWBROOK AT MA						
GRANTEE: ETS WILLOWBROOK PRO						

BUILDING NOTES

BUILDING DIMENSIONS
BAS= W18 FOP= N2 W9 S2 E2 S2 E5 N2 E2\$ W2 S2 W5 N2 W20 S56 W15 N10 KTG= N38 W25 S38 E25\$ W25 N28 FSP= N10 W20 S10 E20\$ W20 S38 W15 N56 W18 FOP= N2 W9 S2 E2 S2 E5 N2 E2\$ W2 S2 W5 N2 W20 S56 W2 S24 E2 S42 E18 FOP= S2 E9 N2 W2 N2 W5 S2 W2\$ E2 N2 E5 S2 E20 N42 E15 S32 E2 CAN= S12 E8 S16 E25 N16 E8 N12 W41\$ E43 N32 E15 S42 E18 FOP= S2 E9 N2 W2 N2 W5 S2 W2\$ E2 N2 E5 S2 E20N40 BAS= E15 S63 E22 FOP= S2 E5 N4 W5 S2\$ N2 E5 S2 E22 N49 UOP= E10 N32 W10 S32\$ N96 W22 FOP= S2 W5 N4 E5 S2\$ S2 W5 N2 W22 S58 W13 N2 W2 S26\$ N82\$ PTR= N60 UUS= N51 E16 N5 W16 N38 W15 S94 E15\$ S60\$.

