

COMM NW COR OF NE1/4 OF SW1/4,  
S3 DEG E 653.03 FT, N 87 DEG E  
913.94 FT FOR POB, CONT E

CURRAN ERIK MICHAEL/HAWKINS LAUREN RENEE  
444 SW SERENITY GLN  
HIGH SPRINGS, FL 32643

2026

04-7S-17-09889-005



ELEMENT		CD	CONSTRUCTION		
Exterior Wall	32		HARDIE BRD	100	
Roof Structur	03		GABLE/HIP	100	
Roof Cover	14		PREFIN MT	100	
Interior Wall	05		DRYWALL	100	
Interior Floor	12		HARDWOOD	90	
Interior Floor	14		CARPET	10	
Air Condition	03		CENTRAL	100	
Heating Type	04		AIR DUCTED	100	
Bedrooms			3	100	
Bathrooms			2	100	
Frame	02		WOOD FRAME	100	
Stories	1.		1.	100	
Architectual Units	05		CONV	100	
			0	100	
Quality	07		07		
DOR CODE	5000 IMPROVED AG				
MAP NUM		MKT AREA	02		
NEIGHBORHOOD/LOC	4717.0200 1.00/				
AREA TYPE	TOTAL GROSS AREA	PCT OF BASE	YEAR	TOT ADJ AREA	SUBAREA MARKET VALUE
BAS	1,391	100		1,391	206,369
FOP	25	30		8	1,187
FOP	221	30		66	9,792
PTO	352	5		18	2,671
UAT	300	10		30	4,451
TOTALS	2,289			1,513	224,469

MARKET ADJUSTMENTS											
TYPE	MDL	EFF. AREA	TOT ADJ PTS	EFF. BASE RATE	REPL. COST NEW	AYB	EYB	ECON	FNCT	NORM	% COND
1	SINGLE FAM	100%	- 2020								
				Heated Area: 1391			HX Base Yr 2020				

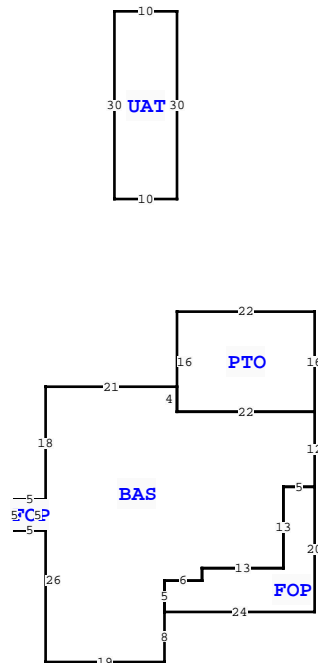

COLUMBIA COUNTY PROPERTY		PAGE 1 of 1	3
VALUATION BY		STANDARD	
Tax Group: 3		Tax Dist:	
BUILDING MARKET VALUE		224,469	
TOTAL MARKET OB/XF VALUE		1,500	
TOTAL LAND VALUE - MARKET		111,210	
TOTAL MARKET VALUE		272,854	
SOH/AGL Deduction		69,484	
ASSESSED VALUE		203,370	
TOTAL EXEMPTION VALUE		51,411	
BASE TAXABLE VALUE		151,959	
TOTAL JUST VALUE		337,179	
NCON VALUE		0	
INCOME VALUE			
PREVIOUS YEAR MKT VALUE		324,402	

PERMIT NUM	DESCRIPTION	AMT	ISSUED
37016	SFR	622	07/25/2018

SALES DATA						
OFF RECORD Number	DATE	TYPE INST	Q / U	V / I	RSN CD	SALE PRICE
1341/0664	7/20/2017	WD	U	V	11	100

GRANTOR: MICHAEL THOMAS CURRAN  
GRANTEE: ERIK MICHAEL CURRAN

BUILDING NOTES	
444 SW SERENITY GLN, HIGH SPRINGS	
BLD DATE: 05/06/2026 MLU	
LGL DATE: 05/06/2026 MLU	
LAND DATE: 05/06/2026 MLU	
AG DATE: 05/06/2026 MLU	

BUILDING DIMENSIONS	
BAS= W21 S18 FOP= W5 S5 E5 N5\$ S26 E19 N8 FOP= E24 N20 W5 S13 W13 S2 W6 S5\$ N5 E6 N2 E13 N13 E5 N12 PTO= N16 W22 S16 E22\$ W22 N4\$ PTR= N30 UAT= N30 W10 S30 E10\$ S30\$.	

EXTRA FEATURES																
L N	OB/XF CODE	DESCRIPTION	BLD CAP	L	W	UNITS	UT	Adj R	ADJ UNIT PRICE	ORIG COND	YEAR ON	YEAR ACTUAL	Q	% COND	OB/XF MKT VALUE	NOTES
1	0296	SHED METAL	0	100	0	0			0.00	100	2019	2019	3	100	1,500	

LAND DESCRIPTION															TOTAL OB/XF									
L N	USE CODE	CLS	LAND USE DESCRIPTION	CAP	R D	LOC ZONE	FRONT	DEPTH	TOT LND UTS	UNIT TYPE	D T	DPH FACT	% COND	TOT ADJ	UNIT PRICE	ADJ UNIT PRICE	LAND VALUE	OTHER ADJUSTMENTS AND NOTES	YEAR	DENSITY	DECL	FRZ	YR	CONSRV
1	0100	C	SFR	100		A-1	0.00	0.00	4.01	AC		1.00	1.00	1.00	11,000.00	11,000.00	44,110							
2	5500	A	TIMBER 2	100					5.00	AC		1.00	1.00	1.00	445.00	445.00	2,225							
3	6677	A	PECANS	100					1.10	AC		1.00	1.00	1.00	500.00	500.00	550							
4	9910	M	MKT. VAL. AG	100					6.10	AC		1.00	1.00	1.00	11,000.00	11,000.00	67,100							