

BUILDING CHARACTERISTICS		CONSTRUCTION	
ELEMENT	CD		
Exterior Wall	05	AVERAGE	100
Roof Structur	03	GABLE/HIP	100
Roof Cover	03	COMP SHNGL	100
Interior Wall	05	DRYWALL	100
Interior Floor	12	HARDWOOD	60
Interior Floor	15	HARDTILE	40
Air Condition	03	CENTRAL	100
Heating Type	04	AIR DUCTED	100
Bedrooms		4	100
Bathrooms		3	100
Frame	01	NONE	100
Stories	1.5	1.5	100
Architectural	05	CONV	100
Units		0	100
Condition Adj	02	02	100
Kitchen Adjus	01	01	100
Quality	05	05	
DOR CODE	0100	SINGLE FAMILY	
MAP NUM		MKT AREA	06
NEIGHBORHOOD/LOC	3417.00	1.00/	
AREA TYPE	TOTAL GROSS AREA	PCT OF BASE	YEAR
BAS	1,755	100	
FHS	504	60	
FOP	45	30	
PTO	718	5	
TOTALS	3,022		

MARKET ADJUSTMENTS													
TYPE	MDL	EFF. AREA	TOT ADJ PTS	EFF. BASE RATE	REPL. COST NEW	AYB	EYB	ECON	FNCT	NORM	% COND		
1	SINGLE FAM	0%	- 2026	118.40	249,469	1985	1985	0	0	35.00	65.00	Heated Area: 2259 HX Base Yr	

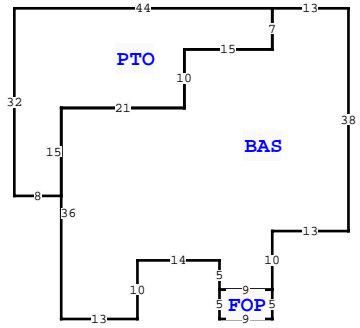
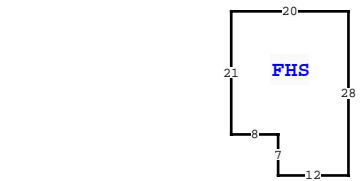

BLD DATE		LGL DATE	
XF DATE		LAND DATE	
INC DATE		AG DATE	

276 SE MORNING GLORY CT, LAKE CITY

EXTRA FEATURES																	
L N	OB/XF CODE	DESCRIPTION	BLD	CAP	L	W	UNITS	UT	Adj R	ADJ UNIT PRICE	ORIG COND	YEAR ON	YEAR ACTUAL	Q	% COND	OB/XF MKT VALUE	NOTES
1	0258	PATIO	0	0	0	0	1.00	UT	0.00	0.00	100	0	0	3	100	500	
2	0180	FPLC 1STRY	0	0	0	0	1.00	UT	2,000.00	2,000.00	100	0	0	3	100	2,000	
3	0166	CONC,PAVMT	0	0	0	0	1.00	UT	0.00	0.00	100	2012	2012	3	100	200	

TOTAL OB/XF 2,700

LAND DESCRIPTION																								
L N	USE CODE	CLS	LAND USE DESCRIPTION	CAP	R D	LOC ZONE	FRONT	DEPTH	TOT LND UTS	UNIT TYPE	D T	DPH FACT	% COND	TOT ADJ	UNIT PRICE	ADJ UNIT PRICE	LAND VALUE	OTHER ADJUSTMENTS AND NOTES	YEAR	DENSITY	DECL	FRZ	YR	CONSRV
1	0100	C	SFR	0		A-1	0.00	0.00	1.00	AC		1.00	1.00	1.00	13,500.00	13,500.00	13,500							

COLUMBIA COUNTY PROPERTY			
VALUATION SUMMARY			PAGE 1 of 1
VALUATION BY		STANDARD	
Tax Group: 2		Tax Dist:	
BUILDING MARKET VALUE		162,155	
TOTAL MARKET OB/XF VALUE		2,700	
TOTAL LAND VALUE - MARKET		13,500	
TOTAL MARKET VALUE		178,355	
SOH/AGL Deduction		0	
ASSESSED VALUE		178,355	
TOTAL EXEMPTION VALUE		0	
BASE TAXABLE VALUE		178,355	
TOTAL JUST VALUE		178,355	
NCON VALUE		0	
INCOME VALUE			
PREVIOUS YEAR MKT VALUE		178,355	

PERMIT NUM	DESCRIPTION	AMT	ISSUED

SALES DATA						
OFF RECORD Number	DATE	TYPE INST	Q U	V I	RSN CD	SALE PRICE
1303/2569	11/05/2015	WD	U	I	12	59,500
GRANTOR: DEUTSCHE BANK						
GRANTEE: REYMUNDA CASTANEDA						
1274/0459	4/23/2014	CT	U	I	18	100
GRANTOR: CLERK OF COURT (GAIL C						
GRANTEE: DEUTSCHE BANK NATIO						

BUILDING NOTES													

BUILDING DIMENSIONS													
BAS= W13 PTO= W44 S32 E8 N15 E21 N10 E15 N7\$ S7 W15 S10 W21 S36 E13 N10 E14 S5 FOP= S5 E9 N5 W9\$ E9 N10E13 N38\$ PTR=N30 FHS= N28 W20 S21 E8 S7 E12\$ S30\$.													