

BUILDING CHARACTERISTICS		CONSTRUCTION	
ELEMENT	CD		
Exterior Wall	16	WD FR STUC	80
Exterior Wall	12	CEDAR	20
Roof Structure	03	GABLE/HIP	100
Roof Cover	03	COMP SHNGL	100
Interior Wall	05	DRYWALL	100
Interior Floor	11	CLAY TILE	80
Interior Floor	12	HARDWOOD	20
Air Condition	03	CENTRAL	100
Heating Type	04	AIR DUCTED	100
Bedrooms		4	100
Bathrooms		3	100
Frame	02	WOOD FRAME	100
Stories	2.	2.	100
Architectual	05	CONV	100
Units		0	100
Quality	07	07	
DOR CODE	0100	SINGLE FAMILY	
MAP NUM		MKT AREA	01
NEIGHBORHOOD/LOC	1516.0500	1.00/	
AREA TYPE	TOTAL GROSS AREA	PCT OF BASE	YEAR
BAS	1,493	100	
FGR	636	55	
FOP	364	30	
FUS	1,262	100	
UST	36	45	
TOTALS	3,791		

MARKET ADJUSTMENTS											
TYPE	MDL	EFF. AREA	TOT ADJ PTS	EFF. BASE RATE	REPL. COST NEW	AYB	EYB	ECON	FNCT	NORM	% COND
0100	01	3,230	135.1142	151.33	488,796	2011	2011	0	0	19.60	80.40
1 SINGLE FAM			100% - 2012	Heated Area: 2755			HX Base Yr 2012				

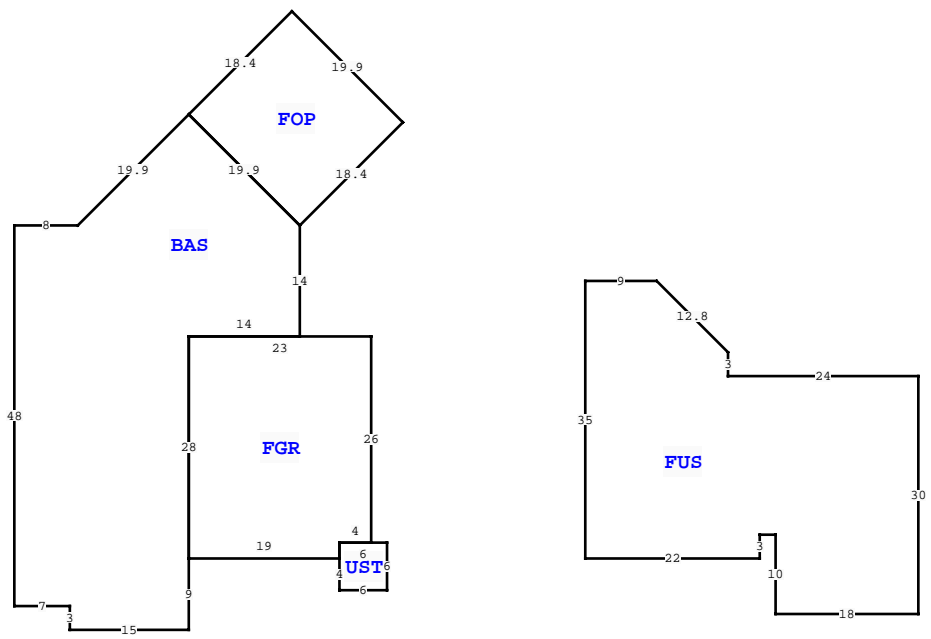

COLUMBIA COUNTY PROPERTY		PAGE 1 of 1	3
VALUATION SUMMARY			
VALUATION BY			STANDARD
Tax Group: 3	Tax Dist:		
BUILDING MARKET VALUE			392,992
TOTAL MARKET OB/XF VALUE			6,500
TOTAL LAND VALUE - MARKET			60,000
TOTAL MARKET VALUE			459,492
SOH/AGL Deduction			129,614
ASSESSED VALUE			329,878
TOTAL EXEMPTION VALUE	HX HB		51,411
BASE TAXABLE VALUE			278,467
TOTAL JUST VALUE			459,492
NCON VALUE			0
INCOME VALUE			
PREVIOUS YEAR MKT VALUE			461,335

PERMIT NUM	DESCRIPTION	AMT	ISSUED
000055146	Roof Replacement	35,600	03/03/2026
28141	SFR	1,031	10/12/2009

SALES DATA						
OFF RECORD Number	DATE	TYPE INST	Q / U	V / I	RSN CD	SALE PRICE
1004/2170	1/14/2004	WD Q	Q	V		58,000
GRANTOR: CHRUSTOPHER J CURRY						
GRANTEE: DAVID M DOSOSWAY						
0898/0160	3/01/2000	WD Q	Q	V		49,900
GRANTOR: WESTFIELD GROUP LTD						
GRANTEE: C CURRY						

EXTRA FEATURES											
L N	OB/XF CODE	DESCRIPTION	BLD CAP	L	W	UNITS	UT	Adj R	ADJ UNIT PRICE	ORIG COND	YEAR ON
1	0166	CONC,PAVMT	0	100	0	1.00	UT	0.00	0.00	100	2019

TOTAL OB/XF												6,500			
BLD DATE	XF DATE	INC DATE	LGL DATE	LAND DATE	AG DATE										
			04/22/2026			MLU									

BUILDING NOTES											

BUILDING DIMENSIONS											
BAS= N28 E14 N14 FOP= R13 U13 U14 L14 L13 D13 D14 R14 \$ L14 U14 L14 D14 W8 S48 E7 S3 E15 N9 FGR= E19 UST= S4 E6 N6 W6 S2\$ N2 E4 N26 W23 S28\$ PTR= E50 FUS= E22 N3 E2 S10 E18 N30 W24 N3 U9 L9 W9 S35\$ W50\$.											

LAND DESCRIPTION												TOTAL OB/XF												
L N	USE CODE	CLS	LAND USE DESCRIPTION	CAP	R D	LOC ZONE	FRONT	DEPTH	TOT LND UTS	UNIT TYPE	D T	DPH FACT	% COND	TOT ADJ	UNIT PRICE	ADJ UNIT PRICE	LAND VALUE	OTHER ADJUSTMENTS AND NOTES	YEAR	DENSITY	DECL	FRZ	YR	CONSRV
1	0100	C	SFR	100		A-3	0.00	0.00	5.00	AC		1.00	1.00	1.00	12,000.00	12,000.00	60,000							