

FORT WHITE: ALL BLK 49 & THAT P
 LYING N & E OF SW US HWY-27. ALS
 OF HARRINGTON ST LYING BETWEEN 4

HEFLIN MARY JO/BRADLEY GLORIA
 170 SW DURANT ST
 FORT WHITE, FL 32038

2026

00-00-00-14402-000

BUILDING CHARACTERISTICS		CONSTRUCTION	
ELEMENT	CD		
Exterior Wall	26	ALM SIDING 100	
Roof Structur	03	GABLE/HIP 100	
Roof Cover	03	COMP SHNGL 100	
Interior Wall	04	PLYWOOD 100	
Interior Floor	14	CARPET 90	
Interior Floor	06	VINYL ASB 10	
Air Condition	02	WINDOW 100	
Heating Type	02	CONVECTION 100	
Bedrooms		3 100	
Bathrooms		1 100	
Frame	01	NONE 100	
Stories	1.	1. 100	
Architectual	05	CONV 100	
Units		0 100	
Condition Adj	03	03 100	
Kitchen Adjus	01	01 100	
Quality	05	05	
DOR CODE	0100	SINGLE FAMILY	
MAP NUM		MKT AREA	02
NEIGHBORHOOD/LOC	16.00	1.00/	
AREA TYPE	TOTAL GROSS AREA	PCT OF BASE	YEAR
BAS	1,284	100	
UCP	400	20	
UDU	280	55	
UOP	32	20	
TOTALS	1,996		

MARKET ADJUSTMENTS											
TYPE	MDL	EFF. AREA	TOT ADJ PTS	EFF. BASE RATE	REPL. COST NEW	AYB	EYB	ECON	FNCT	NORM	% COND
1	SINGLE FAM	100%	- 2022								
Heated Area: 1284						HX Base Yr 2022					

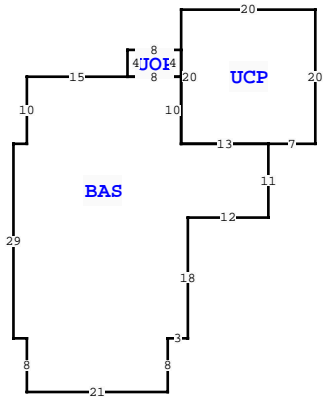
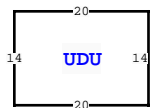

COLUMBIA COUNTY PROPERTY		PAGE 1 of 1	4
VALUATION SUMMARY			
VALUATION BY			STANDARD
Tax Group: 4		Tax Dist:	
BUILDING MARKET VALUE			108,193
TOTAL MARKET OB/XF VALUE			2,050
TOTAL LAND VALUE - MARKET			63,165
TOTAL MARKET VALUE			173,408
SOH/AGL Deduction			9,924
ASSESSED VALUE			163,484
TOTAL EXEMPTION VALUE	HX HB SX		100,722
BASE TAXABLE VALUE			62,762
TOTAL JUST VALUE			173,408
NCON VALUE			0
INCOME VALUE			
PREVIOUS YEAR MKT VALUE			173,408

PERMIT NUM	DESCRIPTION	AMT	ISSUED
32503	MAINT/ALTR	25	12/02/2014
13740	M H	125	03/09/1998

SALES DATA						
OFF RECORD Number	DATE	TYPE INST	Q / U	V / I	RSN CD	SALE PRICE
1433/2124	3/23/2021	WD	U	I	30	100
GRANTOR: HEFLIN MARY JO						
GRANTEE: HEFLIN MARY JO						
1430/495	2/11/2021	PB	U	I	18	0
GRANTOR: CLERK OF COURT						
GRANTEE: HEFLIN MARY JO						

EXTRA FEATURES		TOTALS	
L N	OB/XF CODE	DESCRIPTION	ADJ UNIT PRICE
1	9910	RV SITE/RE	2,000.00
2	0294	SHED WOOD/	0.00
3	0166	CONC, PAVMT	0.00
4	0120	CLFENCE 4	0.00
5	0169	FENCE/WOOD	0.00

L N	OB/XF CODE	DESCRIPTION	BLD CAP	L	W	UNITS	UT	Adj R	ADJ UNIT PRICE	ORIG COND	YEAR ON	YEAR ACTUAL	Q	% COND	OB/XF MKT VALUE	NOTES
1	9910	RV SITE/RE	0	100	0	1.00	UT	2,000.00	2,000.00	100	1998	1998	3	100	1,150	
2	0294	SHED WOOD/	0	100	0	1.00	UT	0.00	0.00	100	2006	2006	3	100	400	
3	0166	CONC, PAVMT	0	100	0	1.00	UT	0.00	0.00	100	2015	2015	3	100	300	
4	0120	CLFENCE 4	0	100	0	1.00	UT	0.00	0.00	100	2015	2015	3	100	100	
5	0169	FENCE/WOOD	0	100	0	1.00	UT	0.00	0.00	100	2015	2015	3	100	100	

BLD DATE		LGL DATE	
XF DATE		LAND DATE	
INC DATE		AG DATE	

BUILDING NOTES	
170 SW DURANT ST, FORT WHITE	

BUILDING DIMENSIONS	
BAS= W15 S10 W2 S29 E2 S8 E21N8 E3 N18 E12 N11 UCP= E7 N20W20 S20 E13\$ W13 N10 UOP= N4 W8 S4 E8\$ W8\$ PTR= N50 UDU= W20 S14 E20 N14\$ S50\$.	

LAND DESCRIPTION		TOTAL OB/XF														2,050								
L N	USE CODE	CLS	LAND USE DESCRIPTION	CAP	R D	LOC ZONE	FRONT	DEPTH	TOT LND UTS	UNIT TYPE	D T	DPH FACT	% COND	TOT ADJ	UNIT PRICE	ADJ UNIT PRICE	LAND VALUE	OTHER ADJUSTMENTS AND NOTES	YEAR	DENSITY	DECL	FRZ	YR	CONSRV
1	0100	C	SFR	100		00	0.00	0.00	42,110.00	SF		1.00	1.00	0.50	3.00	1.50	63,165							