

S DIV: LOTS 3 & 4 BLOCK 2 LAKE V
 NW COR LOT 4, RUN NW TO SEC LINE
 LINE 290.70 FT, SE TO NW COR LOT

DILDAY MICHAEL PAUL/DILDAY KASEY LEE
 385 SW MONTGOMERY DR
 LAKE CITY, FL 32025

2026

00-00-00-13997-000

ELEMENT	CD	CONSTRUCTION
Exterior Wall	16	WD FR STUC 50
Exterior Wall	19	COMMON BRK 50
Roof Structure	08	IRREGULAR 100
Roof Cover	03	COMP SHNGL 100
Interior Wall	04	PLYWOOD 50
Interior Wall	05	DRYWALL 50
Interior Floor	14	CARPET 80
Interior Floor	12	HARDWOOD 20
Air Condition	03	CENTRAL 100
Heating Type	04	AIR DUCTED 100
Bedrooms		5 100
Bathrooms		4.5 100
Frame	01	NONE 100
Stories	2.	2. 100
Architectural	05	CONV 100
Units		0 100
Condition Adj	03	03 100
Kitchen Adjus	01	01 100
Quality	05	05

TYPE	MDL	EFF. AREA	TOT ADJ PTS	EFF. BASE RATE	REPL. COST NEW	AYB	EYB	ECON	FNCT	AP	NORM	% COND
0100	01	6,146	114.3776	128.10	787,303	1946	1980	0	0	10	35.00	55.00

1 SINGLE FAM 100% - 2023 Heated Area: 5304 HX Base Yr 2023

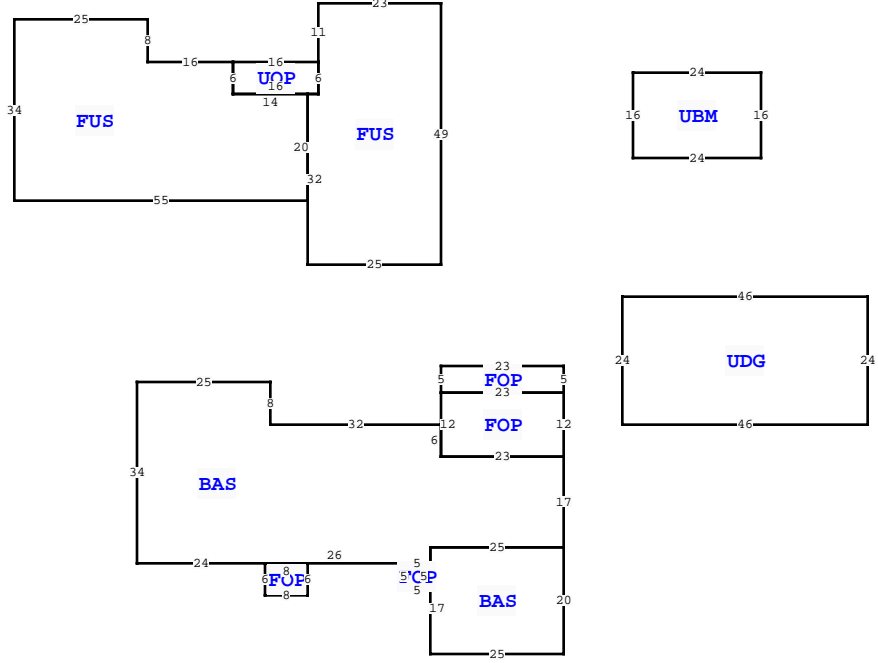

** This building has 11 Sub-Areas

BLD DATE	LGL DATE
XF DATE	LAND DATE
INC DATE	AG DATE

MAP NUM	MKT AREA	06
32317.140	1.00/	

AREA TYPE	TOTAL GROSS AREA	PCT OF BASE	YEAR	TOT ADJ AREA	SUBAREA MARKET VALUE
BAS	500	100		500	35,228
BAS	2,067	100		2,067	145,631
FOP	25	30		8	564
FOP	48	30		14	986
FOP	115	30		34	2,395
FOP	276	30		83	5,848
FUS	1,191	100		1,191	83,912
FUS	1,546	100		1,546	108,924
UBM	384	20		77	5,425
UDG	1,104	55		607	42,766
TOTALS	7,352			6,146	433,017

L N	OB/XF CODE	DESCRIPTION	BLD	CAP	L	W	UNITS	UT	Adj R	ADJ UNIT PRICE	ORIG COND	YEAR ON	YEAR ACTUAL	Q	% COND	OB/XF MKT VALUE	NOTES
1	0166	CONC,PAVMT	0	100	0	0	1.00	UT	0.00	0.00	100	0	0	3	100	3,000	
2	0170	FPLC 2STRY	0	100	0	0	2.00	UT	2,750.00	2,750.00	100	0	0	3	100	5,500	
3	0258	PATIO	0	100	0	0	1.00	UT	0.00	0.00	100	0	0	3	100	200	
4	0280	POOL R/CON	0	100	16	32	512.00	UT	168.00	168.00	30	1970	1970	3	30	25,805	
5	0119	MASONRY WA	0	100	0	0	1.00	UT	0.00	0.00	100	2017	2017	3	100	200	

EXTRA FEATURES																
385 SW MONTGOMERY DR, LAKE CITY																
TOTAL OB/XF 34,705																

L N	USE CODE	CLS	LAND USE DESCRIPTION	CAP	R D	LOC ZONE	FRONT	DEPTH	TOT LND UTS	UNIT TYPE	D T	DPHT FACT	% COND	TOT ADJ	UNIT PRICE	ADJ UNIT PRICE	LAND VALUE	OTHER ADJUSTMENTS AND NOTES	YEAR	DENSITY	DECL	FRZ	YR	CONSRV
1	0133	C	SFR LAKE	100		00	0.00	0.00	240.00	FF		1.00	1.00	1.00	325.00	325.00	78,000							

COLUMBIA COUNTY PROPERTY PAGE 1 of 1																							
VALUATION SUMMARY																							
VALUATION BY												STANDARD											
Tax Group: 1												Tax Dist:											
BUILDING MARKET VALUE												433,017											
TOTAL MARKET OB/XF VALUE												34,705											
TOTAL LAND VALUE - MARKET												78,000											
TOTAL MARKET VALUE												545,722											
SOH/AGL Deduction												16,747											
ASSESSED VALUE												528,975											
TOTAL EXEMPTION VALUE												HX HB 51,411											
BASE TAXABLE VALUE												477,564											
TOTAL JUST VALUE												545,722											
NCON VALUE												0											
INCOME VALUE																							
PREVIOUS YEAR MKT VALUE												545,722											

PERMIT NUM	DESCRIPTION	AMT	ISSUED
1146	MAINT/ALTR	0	12/31/2015
3536	ADDN SFR	70	02/13/2006
012	SFR	50,000	01/27/1994

SALES DATA						
OFF RECORD Number	DATE	TYPE INST	Q U	V I	RSN CD	SALE PRICE
1473/1274	8/11/2022	WD Q	Q	I	01	601,100

GRANTOR: SCRIVENER LIVING TRUS						
GRANTEE: DILDAY MICHAEL PAUL						
1437/1437	5/03/2021	WD Q	Q	I	01	499,900
GRANTOR: REICHERT RICHARD W						
GRANTEE: SCRIVENER LIVING TR						

BUILDING NOTES																
----------------	--	--	--	--	--	--	--	--	--	--	--	--	--	--	--	--

BUILDING DIMENSIONS																
BAS=[ORIG=0,0] W32 N8 W25 S34 E24 E26 E5 N3 E25 N17 W23 N6 \$																
FUS=[ORIG=-25,-62] W14 N6 W16 N8 W25 S34 E55 N20 \$																
FUS=[ORIG=0,-30] N49 W23 S11 S6 W2 S32 E25 \$																
UDG=[ORIG=80,0] N24 W46 S24 E46 \$																
BAS=[ORIG=-2,26] S17 E25 N20 W25 S3 \$																
UBM=[ORIG=60,-50] N16 W24 S16 E24 \$																
FOP=[ORIG=23,6] N12 W23 S12 E23 \$																
FOP=[ORIG=23,-6] N5 W23 S5 E23 \$																
UOP=[ORIG=-23,-68] W16 S6 E16 N6 \$																
FOP=[ORIG=-33,26] S6 E8 N6 W8 \$																
FOP=[ORIG=-7,26] S5 E5 N5 W5 \$																