

BUILDING CHARACTERISTICS		CONSTRUCTION	
ELEMENT	CD		
Exterior Wall	17	MSNRY STUC	100
Roof Structur	03	GABLE/HIP	100
Roof Cover	03	COMP SHNGL	100
Interior Wall	05	DRYWALL	100
Interior Floo	14	CARPET	100
Ceiling	02	F.NOT SUS	100
Air Condition	03	CENTRAL	100
Heating Type	04	AIR DUCTED	100
Fixtures	16	100	
Frame	03	MASONRY	100
Story Height	0	100	
RMS	10	100	
Stories	2.	2.100	
Units	0	100	
Condition Adj	03	03	100
Quality	05	05	
DOR CODE	7100	CHURCHES-EX	
MAP NUM		MKT AREA	06
NEIGHBORHOOD/LOC	860317.00	1.00/	
AREA TYPE	TOTAL GROSS AREA	PCT OF BASE	YEAR
BAS	456	100	
BAS	3,217	100	
FOP	60	30	
FSP	54	40	
FST	54	50	
FUS	1,157	100	
TOTALS	4,998		

MARKET ADJUSTMENTS													
TYPE	MDL	EFF. AREA	TOT ADJ PTS	EFF. BASE RATE	REPL. COST NEW	AYB	EYB	ECON	FNCT	NORM	% COND		
1	CHURCH	0%	- 0									Heated Area: 4830 HX Base Yr	

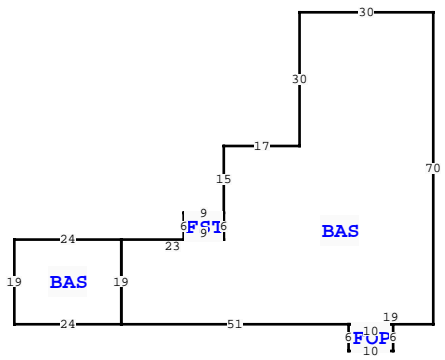
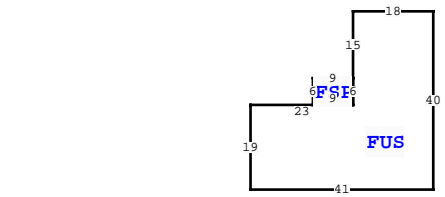

COLUMBIA COUNTY PROPERTY		PAGE 1 of 2	1
VALUATION SUMMARY			
VALUATION BY		STANDARD	
Tax Group: 1	Tax Dist:		
BUILDING MARKET VALUE		683,556	
TOTAL MARKET OB/XF VALUE		5,036	
TOTAL LAND VALUE - MARKET		25,930	
TOTAL MARKET VALUE		714,522	
SOH/AGL Deduction		0	
ASSESSED VALUE		714,522	
TOTAL EXEMPTION VALUE	02	714,522	
BASE TAXABLE VALUE		0	
TOTAL JUST VALUE		714,522	
NCON VALUE		0	
INCOME VALUE			
PREVIOUS YEAR MKT VALUE		713,446	

PERMIT NUM	DESCRIPTION	AMT	ISSUED
1594	SFR	38	07/26/1999
863	ADDN COMM	5	12/18/1996
080	CHURCH	20,000	04/28/1992

SALES DATA						
OFF RECORD Number	DATE	TYPE INST	Q / U	V / I	RSN CD	SALE PRICE
0782/2063	11/22/1993	QC	Q	I	01	0

GRANTOR: CLYDE DOUGLAS
GRANTEE: COMMUNITY REVIVAL

BUILDING DIMENSIONS	
BAS= W30 S30 W17 S15 FST= W9S6 E9 N6S S6 W23 BAS= W24 S19E24 N19S S19 E51 FOP= S6 E10N6 W10S E19 N70S PTR=N30 FUS= N40 W18 S15 FSP= W9 S6 E9 N6S S6 W23 S19 E41S S30S.	

BUILDING NOTES	

EXTRA FEATURES														761 NE LAKE DR, LAKE CITY		
L N	OB/XF CODE	DESCRIPTION	BLD CAP	L	W	UNITS	UT	Adj R	ADJ UNIT PRICE	ORIG COND	YEAR ON	YEAR ACTUAL	Q	% COND	OB/XF MKT VALUE	NOTES
1	0258	PATIO	0	0	0	1.00	UT	0.00	0.00	100	0	0	3	100	100	
2	0010	BARN, BLK	0	0	0	1.00	UT	0.00	0.00	100	0	0	3	100	1,000	
3	0010	BARN, BLK	0	0	0	1.00	UT	0.00	0.00	100	0	0	3	100	500	
4	0166	CONC, PAVMT	0	0	0	1,718.00	UT	2.00	2.00	100	2002	2002	3	100	3,436	

LAND DESCRIPTION														TOTAL OB/XF									
L N	USE CODE	CLS	LAND USE DESCRIPTION	CAP	R D	LOC ZONE	FRONT	DEPTH	TOT LND UTS	UNIT TYPE	DPTH FACT	% COND	TOT ADJ	UNIT PRICE	ADJ UNIT PRICE	LAND VALUE	OTHER ADJUSTMENTS AND NOTES	YEAR	DENSITY	DECL	FRZ	YR	CONSRV
1	7100	C	CHURCH	0		*RMF	220.00	430.00	94,600.00	SF	1.00	1.00	0.37	0.75	0.27	25,930							

