

BUILDING CHARACTERISTICS		CONSTRUCTION	
ELEMENT	CD		
Exterior Wall	19	COMMON BRK	100
Roof Structur	03	GABLE/HIP	100
Roof Cover	12	MODULAR MT	100
Interior Wall	04	PLYWOOD	100
Interior Floo	14	CARPET	100
Ceiling	02	F.NOT SUS	100
Air Condition	03	CENTRAL	100
Heating Type	04	AIR DUCTED	100
Fixtures	12	100	
Frame	03	MASONRY	100
Story Height	0	100	
RMS	2	100	
Stories	0	100	
Units	0	100	
Condition Adj	03	03	100
Quality	05	05	
DOR CODE	7100	CHURCHES-EX	
MAP NUM		MKT AREA	07
NEIGHBORHOOD/LOC	810317.00	1.00/	
AREA TYPE	TOTAL GROSS AREA	PCT OF BASE	YEAR
BAS	7,478	100	
UOP	50	20	
TOTALS	7,528		
TOTALS		7,488	241,938

MARKET ADJUSTMENTS											
TYPE	MDL	EFF. AREA	TOT ADJ PTS	EFF. BASE RATE	REPL. COST NEW	AYB	EYB	ECON	FNCT	NORM	% COND
1	CHURCH	0%	- 0								
				Heated Area: 7478							
					HX Base Yr						

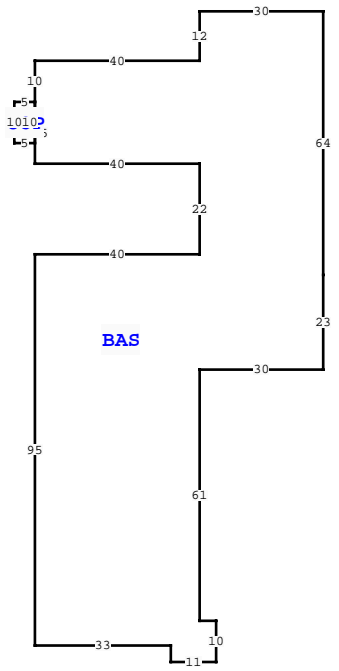

COLUMBIA COUNTY PROPERTY		PAGE 1 of 1	1
VALUATION SUMMARY			
VALUATION BY			STANDARD
Tax Group: 1	Tax Dist:		
BUILDING MARKET VALUE			241,938
TOTAL MARKET OB/XF VALUE			4,811
TOTAL LAND VALUE - MARKET			11,025
TOTAL MARKET VALUE			257,774
SOH/AGL Deduction			0
ASSESSED VALUE			257,774
TOTAL EXEMPTION VALUE	02	257,774	
BASE TAXABLE VALUE			0
TOTAL JUST VALUE			257,774
NCON VALUE			0
INCOME VALUE			
PREVIOUS YEAR MKT VALUE			257,774

PERMIT NUM	DESCRIPTION	AMT	ISSUED
25-0381	REROOF - METAL		04/28/2025
14-0131	REMODEL	75	04/09/2014
682	MAINT/ALTR	0	04/09/2008
359	MAINT/ALTR	50	09/25/2007
079	CHURCH	18,000	04/28/1992

SALES DATA						
OFF RECORD Number	DATE	TYPE INST	Q U	V I	RSN CD	SALE PRICE

EXTRA FEATURES																	
L N	OB/XF CODE	DESCRIPTION	BLD	CAP	L	W	UNITS	UT	Adj R	ADJ UNIT PRICE	ORIG COND	YEAR ON	YEAR ACTUAL	Q	% COND	OB/XF MKT VALUE	NOTES
1	0166	CONC, PAVMT	0	0	0	0	1.00	UT	0.00	0.00	100	0	0	3	100	1,911	
2	0260	PAVEMENT-A	0	0	0	0	1.00	UT	0.00	0.00	100	2011	2011	3	100	1,200	
3	0169	FENCE/WOOD	0	0	0	0	1.00	UT	0.00	0.00	100	2011	2011	3	100	200	
4	0297	SHED CONCR	0	0	0	0	1.00	UT	0.00	0.00	100	2011	2011	3	100	1,200	
5	0297	SHED CONCR	0	0	0	0	1.00	UT	0.00	0.00	100	2015	2015	3	100	200	
6	0169	FENCE/WOOD	0	0	0	0	1.00	UT	0.00	0.00	100	2015	2015	3	100	100	
TOTALS															4,811		

BLD DATE		LGL DATE	
XF DATE	INC DATE	LAND DATE	AG DATE

BUILDING NOTES	

BUILDING DIMENSIONS	
BAS= N64 W30 S12 W40 S10 UOP= W5 S10 E5 N10\$ S15 E40 S22 W40 S95 E33 S4 E11 N10 W4 N61 E30 N23\$.	

LAND DESCRIPTION															TOTAL OB/XF									
L N	USE CODE	CLS	LAND USE DESCRIPTION	CAP	R D	LOC ZONE	FRONT	DEPTH	TOT LND UTS	UNIT TYPE	D T	DPH FACT	% COND	TOT ADJ	UNIT PRICE	ADJ UNIT PRICE	LAND VALUE	OTHER ADJUSTMENTS AND NOTES	YEAR	DENSITY	DECL	FRZ	YR	CONSRV
1	7100	C	CHURCH	0		*RSF	200.00	105.00	21,000.00	SF		1.00	1.00	0.70	0.50	0.35	7,350							
2	7100	C	CHURCH	0		*RSF	105.00	100.00	10,500.00	SF		1.00	1.00	0.70	0.50	0.35	3,675							