

LOTS 71, 72 & 73 & BEG NW COR OF
427.06 FT, NE 216.48 FT, SE 100
FT, NW 544.50 FT, NE 102.83 FT T

JARVIS KEITH A
175 SW SANTA FE DR
FORT WHITE, FL 32038

2026

00-00-00-00893-013

ELEMENT	CD	CONSTRUCTION
Exterior Wall	04	SINGLE SID 100
Roof Structur	03	GABLE/HIP 100
Roof Cover	12	MODULAR MT 100
Interior Wall	05	DRYWALL 100
Interior Floor	14	CARPET 80
Interior Floor	06	VINYL ASB 20
Air Condition	03	CENTRAL 100
Heating Type	04	AIR DUCTED 100
Bedrooms		3 100
Bathrooms		2 100
Frame	01	NONE 100
Stories	1.	1. 100
Architectual Units	05	CONV 100
Condition Adj	02	02 100
Kitchen Adjus	01	01 100

TYPE	MDL	EFF. AREA	TOT ADJ PTS	EFF. BASE RATE	REPL. COST NEW	AYB	EYB	ECON	FNCT	AP	NORM	% COND
0100	01	1,743	80.1738	89.79	156,504	1981	1981	0	0	25	35.00	40.00

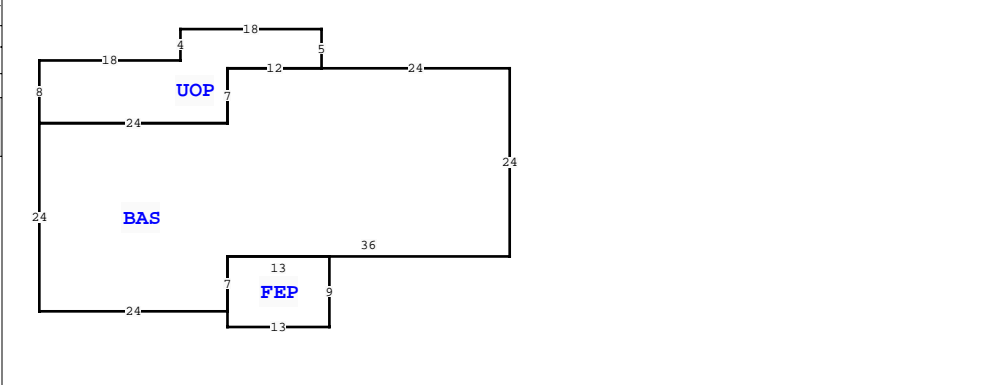

QUALITY	DOR CODE	MAP NUM	MKT AREA	NEIGHBORHOOD/LOC
03 03	0100		02	100000.12 1.00/

AREA TYPE	TOTAL GROSS AREA	PCT OF BASE	YEAR	TOT ADJ AREA	SUBAREA MARKET VALUE
BAS	1,440	100		1,440	51,719
FEP	117	80		94	3,376
UDG	280	55		154	5,531
UOP	276	20		55	1,975
TOTALS	2,113			1,743	62,602

BLD DATE	XF DATE	INC DATE	LGL DATE	LAND DATE	AG DATE
			04/14/2026		

L N	OB/XF CODE	DESCRIPTION	BLD CAP	L	W	UNITS	UT	Adj R	ADJ UNIT PRICE	ORIG COND	YEAR ON	YEAR ACTUAL	Q	% COND	OB/XF MKT VALUE	NOTES
1	0190	FPLC PF	0	100	0	1.00	UT	1,200.00	1,200.00	100	0	0	3	100	1,200	
2	0261	PRCH, UOP	0	100	0	1.00	UT	0.00	0.00	100	2014	2014	3	100	200	

LAND DESCRIPTION	USE CODE	CLS	LAND USE DESCRIPTION	CAP	R D	LOC ZONE	FRONT	DEPTH	TOT LND UTS	UNIT TYPE	D T	DPH FACT	% COND	TOT ADJ	UNIT PRICE	ADJ UNIT PRICE	LAND VALUE	OTHER ADJUSTMENTS AND NOTES	YEAR	DENSITY	DECL	FRZ	YR	CONSRV
1	0100	C	SFR	100		00	0.00	0.00	2.00	LT		1.00	1.00	0.50	24,000.00	12,000.00	24,000							
2	0000	C	VAC RES	100			0.00	0.00	3.30	AC		1.00	1.00	0.20	6,000.00	1,200.00	3,960							

COLUMBIA COUNTY PROPERTY		PAGE 1 of 1	3
VALUATION BY		STANDARD	
Tax Group: 3		Tax Dist:	
BUILDING MARKET VALUE		62,602	
TOTAL MARKET OB/XF VALUE		1,400	
TOTAL LAND VALUE - MARKET		27,960	
TOTAL MARKET VALUE		91,962	
SOH/AGL Deduction		11,865	
ASSESSED VALUE		80,097	
TOTAL EXEMPTION VALUE		51,411	
BASE TAXABLE VALUE		28,686	
TOTAL JUST VALUE		91,962	
NCON VALUE		0	
INCOME VALUE			
PREVIOUS YEAR MKT VALUE		85,962	

PERMIT NUM	DESCRIPTION	AMT	ISSUED
29049	MAINT/ALTR	30	12/07/2010

SALES DATA						
OFF RECORD Number	DATE	TYPE INST	Q U	V I	RSN CD	SALE PRICE
1510/454	9/15/2023	WD	U	I	11	100

GRANTOR: ZUKAS MICHAEL S
GRANTEE: JARVIS KEITH A
1098/2148 10/06/2006 WD Q I 78,000
GRANTOR: GARY L HINSON
GRANTEE: KEITH A JARVIS & MI

BUILDING NOTES	
BUILDING DIMENSIONS	

BAS=[ORIG=0,0] W24 W12 S7 W24 S24 E24 N7 E36 N24 \$
UDG=[ORIG=0,-30] N20 W14 S20 E14 \$
UOP=[ORIG=-24,0] N5 W18 S4 W18 S8 E24 N7 E12 \$
FEP=[ORIG=-36,31] S2 E13 N9 W13 S7 \$