

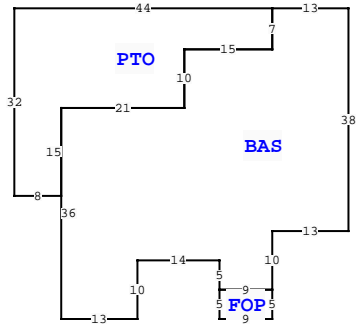

| BUILDING CHARACTERISTICS | | CONSTRUCTION | |
|--------------------------|------------------|---------------|------|
| ELEMENT | CD | | |
| Exterior Wall | 05 | AVERAGE | 100 |
| Roof Structur | 03 | GABLE/HIP | 100 |
| Roof Cover | 03 | COMP SHNGL | 100 |
| Interior Wall | 05 | DRYWALL | 100 |
| Interior Floor | 12 | HARDWOOD | 60 |
| Interior Floor | 15 | HARDTILE | 40 |
| Air Condition | 03 | CENTRAL | 100 |
| Heating Type | 04 | AIR DUCTED | 100 |
| Bedrooms | | 4 | 100 |
| Bathrooms | | 3 | 100 |
| Frame | 01 | NONE | 100 |
| Stories | 1.5 | 1.5 | 100 |
| Architectual Units | 05 | CONV | 100 |
| Condition Adj | 02 | 02 | 100 |
| Kitchen Adjus | 01 | 01 | 100 |
| Quality | 05 | 05 | |
| DOR CODE | 0100 | SINGLE FAMILY | |
| MAP NUM | | MKT AREA | 06 |
| NEIGHBORHOOD/LOC | 3417.00 | 1.00/ | |
| AREA TYPE | TOTAL GROSS AREA | PCT OF BASE | YEAR |
| BAS | 1,755 | 100 | |
| FHS | 504 | 60 | |
| FOP | 45 | 30 | |
| PTO | 718 | 5 | |
| TOTALS | 3,022 | | |

| MARKET ADJUSTMENTS | | | | | | | | | | | |
|--------------------|------------|-----------|-------------|-------------------|-----------------|------|------|------|------|-------|--------|
| TYPE | MDL | EFF. AREA | TOT ADJ PTS | EFF. BASE RATE | REPL. COST NEW | AYB | EYB | ECON | FNCT | NORM | % COND |
| 1 | SINGLE FAM | - 100% | - 2019 | | 240,556 | 1985 | 1985 | 0 | 0 | 35.00 | 65.00 |
| | | | | Heated Area: 2259 | | | | | | | |
| | | | | | HX Base Yr 2019 | | | | | | |

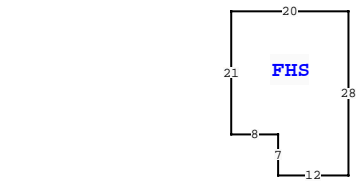

| | | | |
|----------|--|-----------|--|
| BLD DATE | | LGL DATE | |
| XF DATE | | LAND DATE | |
| INC DATE | | AG DATE | |

276 SE MORNING GLORY CT, LAKE CITY

| EXTRA FEATURES | | | | | | | | | | | |
|----------------|------------|-------------|---------|-----|---|-------|------|-------|----------------|-----------|---------|
| L N | OB/XF CODE | DESCRIPTION | BLD CAP | L | W | UNITS | UT | Adj R | ADJ UNIT PRICE | ORIG COND | YEAR ON |
| 1 | 0258 | PATIO | 0 | 100 | 0 | 0 | 1.00 | UT | 0.00 | 100 | 0 |
| 2 | 0180 | FPLC 1STRY | 0 | 100 | 0 | 0 | 1.00 | UT | 2,000.00 | 100 | 0 |
| 3 | 0166 | CONC,PAVMT | 0 | 100 | 0 | 0 | 1.00 | UT | 0.00 | 100 | 2012 |

TOTAL OB/XF 2,700

| LAND DESCRIPTION | | | | | | | | | | | |
|------------------|----------|-----|----------------------|-----|-----|----------|-------|-------|-------------|-----------|------|
| L N | USE CODE | CLS | LAND USE DESCRIPTION | CAP | R D | LOC ZONE | FRONT | DEPTH | TOT LND UTS | UNIT TYPE | D T |
| 1 | 0100 | C | SFR | 100 | | A-1 | 0.00 | 0.00 | 1.00 | AC | 1.00 |

| TOT ADJ | UNIT PRICE | ADJ UNIT PRICE | LAND VALUE | OTHER ADJUSTMENTS AND NOTES | YEAR | DENSITY | DECL | FRZ | YR | CONSRV |
|---------|------------|----------------|------------|-----------------------------|------|---------|------|-----|----|--------|
| 1.00 | 13,500.00 | 13,500.00 | 13,500 | | | | | | | |

| COLUMBIA COUNTY PROPERTY | | PAGE 1 of 1 | 2 |
|---------------------------|-------|-------------|---|
| VALUATION SUMMARY | | | |
| VALUATION BY | | STANDARD | |
| Tax Group: 2 | | Tax Dist: | |
| BUILDING MARKET VALUE | | 156,361 | |
| TOTAL MARKET OB/XF VALUE | | 2,700 | |
| TOTAL LAND VALUE - MARKET | | 13,500 | |
| TOTAL MARKET VALUE | | 172,561 | |
| SOH/AGL Deduction | | 54,310 | |
| ASSESSED VALUE | | 118,251 | |
| TOTAL EXEMPTION VALUE | HX HB | 50,722 | |
| BASE TAXABLE VALUE | | 67,529 | |
| TOTAL JUST VALUE | | 172,561 | |
| NCON VALUE | | 0 | |
| INCOME VALUE | | | |
| PREVIOUS YEAR MKT VALUE | | 168,220 | |

| PERMIT NUM | DESCRIPTION | AMT | ISSUED |
|------------|-------------|-----|--------|
| | | | |
| | | | |
| | | | |

| SALES DATA | | | | | | |
|---------------------------------|------------|-----------|-------|-------|--------|------------|
| OFF RECORD Number | DATE | TYPE INST | Q / U | V / I | RSN CD | SALE PRICE |
| 1303/2569 | 11/05/2015 | WD | U | I | 12 | 59,500 |
| GRANTOR: DEUTSCHE BANK | | | | | | |
| GRANTEE: REYMUNDA CASTANEDA | | | | | | |
| 1274/0459 | 4/23/2014 | CT | U | I | 18 | 100 |
| GRANTOR: CLERK OF COURT (GAIL C | | | | | | |
| GRANTEE: DEUTSCHE BANK NATIO | | | | | | |

| BUILDING NOTES | | | | | | | | | | | |
|----------------|--|--|--|--|--|--|--|--|--|--|--|
| | | | | | | | | | | | |

| BUILDING DIMENSIONS | | | | | | | | | | | |
|--|--|--|--|--|--|--|--|--|--|--|--|
| BAS= W13 PTO= W44 S32 E8 N15 E21 N10 E15 N7\$ S7 W15 S10 W21 S36 E13 N10 E14 S5 FOP= S5 E9 N5 W9\$ E9 N10E13 N38\$ PTR=N30 FHS= N28 W20 S21 E8 S7 E12\$ S30\$. | | | | | | | | | | | |