

BUILDING CHARACTERISTICS		
ELEMENT	CD	CONSTRUCTION
Exterior Wall	19	COMMON BRK 100
Roof Structur	03	GABLE/HIP 100
Roof Cover	12	MODULAR MT 100
Interior Wall	04	PLYWOOD 100
Interior Floo	14	CARPET 100
Ceiling	02	F.NOT SUS 100
Air Condition	03	CENTRAL 100
Heating Type	04	AIR DUCTED 100
Fixtures	12	100
Frame	03	MASONRY 100
Story Height		0 100
RMS		2 100
Stories	0	0 100
Units		0 100
Condition Adj	03	03 100
Quality	05	05
DOR CODE	7100	CHURCHES-EX
MAP NUM		MKT AREA 07
NEIGHBORHOOD/LOC	810317.00	1.00/
AREA TYPE	TOTAL GROSS AREA	PCT OF BASE
BAS	7,478	100
UOP	50	20
TOTALS	7,528	100

MARKET ADJUSTMENTS												
TYPE	MDL	EFF. AREA	TOT ADJ PTS	EFF. BASE RATE	REPL. COST NEW	AYB	EYB	ECON	FNCT	NORM	% COND	
1	CHURCH	0%	0									
				Heated Area: 7478								
					HX Base Yr							

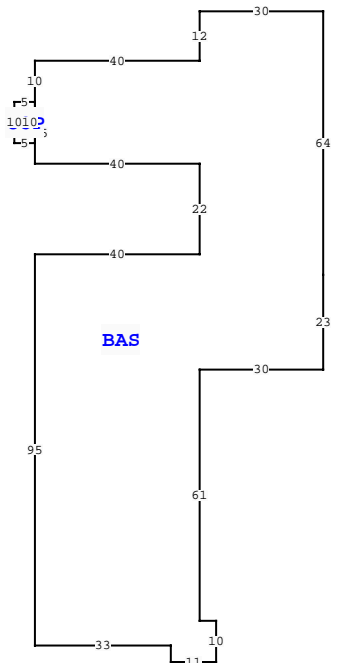

COLUMBIA COUNTY PROPERTY		PAGE 1 of 1	1
VALUATION SUMMARY			
VALUATION BY		STANDARD	
Tax Group: 1	Tax Dist:		
BUILDING MARKET VALUE		241,938	
TOTAL MARKET OB/XF VALUE		4,811	
TOTAL LAND VALUE - MARKET		11,025	
TOTAL MARKET VALUE		257,774	
SOH/AGL Deduction		0	
ASSESSED VALUE		257,774	
TOTAL EXEMPTION VALUE	02	257,774	
BASE TAXABLE VALUE		0	
TOTAL JUST VALUE		257,774	
NCON VALUE		0	
INCOME VALUE		0	
PREVIOUS YEAR MKT VALUE		257,774	

PERMIT NUM	DESCRIPTION	AMT	ISSUED
25-0381	REROOF - METAL		04/28/2025
14-0131	REMODEL	75	04/09/2014
682	MAINT/ALTR	0	04/09/2008
359	MAINT/ALTR	50	09/25/2007
079	CHURCH	18,000	04/28/1992

SALES DATA						
OFF RECORD Number	DATE	TYPE INST	Q / U	V / I	RSN CD	SALE PRICE

EXTRA FEATURES																	
L N	OB/XF CODE	DESCRIPTION	BLD	CAP	L	W	UNITS	UT	Adj R	ADJ UNIT PRICE	ORIG COND	YEAR ON	YEAR ACTUAL	Q	% COND	OB/XF MKT VALUE	NOTES
1	0166	CONC, PAVMT	0	0	0	0	1.00	UT	0.00	0.00	100	0	0	3	100	1,911	
2	0260	PAVEMENT-A	0	0	0	0	1.00	UT	0.00	0.00	100	2011	2011	3	100	1,200	
3	0169	FENCE/WOOD	0	0	0	0	1.00	UT	0.00	0.00	100	2011	2011	3	100	200	
4	0297	SHED CONCR	0	0	0	0	1.00	UT	0.00	0.00	100	2011	2011	3	100	1,200	
5	0297	SHED CONCR	0	0	0	0	1.00	UT	0.00	0.00	100	2015	2015	3	100	200	
6	0169	FENCE/WOOD	0	0	0	0	1.00	UT	0.00	0.00	100	2015	2015	3	100	100	
TOTAL OB/XF 4,811																	

BUILDING NOTES												
550 NE MARTIN LUTHER KING ST, LAKE CITY, FL 32056-0807												

BUILDING DIMENSIONS												
BAS= N64 W30 S12 W40 S10 UOP= W5 S10 E5 N10\$ S15 E40 S22 W40 S95 E33 S4 E11 N10 W4 N61 E30 N23\$.												

LAND DESCRIPTION													TOTAL OB/XF 4,811												
L N	USE CODE	CLS	LAND USE DESCRIPTION	CAP	R D	LOC ZONE	FRONT	DEPTH	TOT LND UTS	UNIT TYPE	D T	DPH FACT	% COND	TOT ADJ	UNIT PRICE	ADJ UNIT PRICE	LAND VALUE	OTHER ADJUSTMENTS AND NOTES	YEAR	DENSITY	DECL	FRZ	YR	CONSRV	
1	7100	C	CHURCH	0		*RSF	200.00	105.00	21,000.00	SF		1.00	1.00	0.70	0.50	0.35	7,350								
2	7100	C	CHURCH	0		*RSF	105.00	100.00	10,500.00	SF		1.00	1.00	0.70	0.50	0.35	3,675								